

JVC

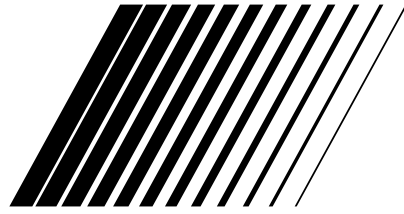

HR-IP820U

VIDEO CASSETTE RECORDER

HR-IP820U

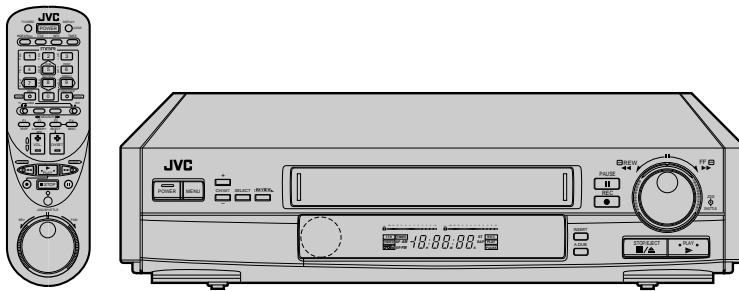

VCR Plus+^{c3}
w/Cable Channel
Changer

INDEX Plus+™

Hi-Fi **VHS**

INSTRUCTIONS

For INDEX Plus+ System operation, refer to the separate INDEX Plus+ instruction manual.

For Customer Use:

Enter below the Serial No. which is located on the rear of cabinet. Retain this information for future reference.

Model No. **HR-IP820U**

Serial No. _____

Safety Precautions

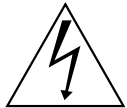
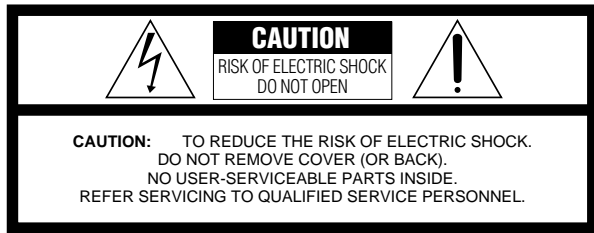

The lightning flash with arrowhead symbol, within an equilateral triangle, is intended to alert the user to the presence of uninsulated "dangerous voltage" within the product's enclosure that may be of sufficient magnitude to constitute a risk of electric shock to persons.



The exclamation point within an equilateral triangle is intended to alert the user to the presence of important operating and maintenance (servicing) instructions in the literature accompanying the appliance.

Note to CATV system installer:

This reminder is provided to call the CATV system installer's attention to Article 820-40 of the NEC that provides guidelines for proper grounding and, in particular, specifies that the cable ground shall be connected to the grounding system of the building, as close to the point of cable entry as practical.

WARNING: TO PREVENT FIRE OR SHOCK HAZARD, DO NOT EXPOSE THIS UNIT TO RAIN OR MOISTURE.

CAUTION:

This video cassette recorder should be used with AC 120V~, 60 Hz only.

To prevent electric shocks and fire hazards, do NOT use any other power source.

CAUTION:

TO PREVENT ELECTRIC SHOCK, MATCH WIDE BLADE OF PLUG TO WIDE SLOT, FULLY INSERT.

ATTENTION:

POUR ÉVITER LES CHOCS ÉLECTRIQUES, INTRODUIRE LA LAME LA PLUS LARGE DE LA FICHE DANS LA BORNE CORRESPONDANTE DE LA PRISE ET POUSSER JUSQU'AU FOND.

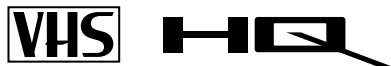

- Cassettes marked "VHS" (or "S-VHS") can be used with this video cassette recorder.
- HQ VHS is compatible with existing VHS equipment.

VCR Plus+ and PlusCode are trademarks of Gemstar Development Corp. VCR Plus+ system is manufactured under licence from Gemstar Development Corporation.

VCR PLUS+, PLUSCODE and INDEX PLUS+ are trademarks of Gemstar Development Corporation. VCR PLUS+ and INDEX PLUS+ Systems are manufactured under license from Gemstar Development Corporation and Index Systems, Inc.

NOTE:

- When you are not using the video recorder for a long period of time, it is recommended that you disconnect the power cord from the AC outlet.
- Changes or modifications not approved by JVC could void user's authority to operate the equipment.
- The rating plate and the safety caution are on the rear of the unit.
- Please read the "Precautions" section of this instruction manual and the "Video Products Safety Guide" enclosed with this manual before installing or operating the VCR.
- This instruction manual, and the other reference materials enclosed with it, contain important information on VCR operation and proper usage. Please keep them near your VCR in a place where you can easily access them for reference.
- It should be noted that it may be unlawful to re-record pre-recorded tapes, records, or discs without the consent of the owner of copyright in the sound or video recording, broadcast or cable program and in any literary, dramatic, musical, or artistic work embodied therein.

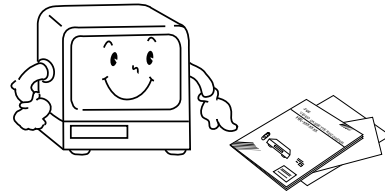

How To Use This Instruction Manual

This instruction manual begins with an introductory section, "Getting To Know Your VCR", followed by the necessary set-up procedures in "Setting Up Your VCR". The next five sections — "Playback", "Recording", "Timer-Recording with VCR Plus+", "Timer-Recording without VCR Plus+" and "Special Features" — take you step-by-step through these operations of your VCR. "Editing" introduces you to your VCR's editing features. "If You Have Any Questions" is the section you should refer to if you experience any problems in VCR operation or if you need additional information regarding a feature or terminology. At the end of the book you will find "Warranty" information and the locations you can contact "For Servicing".

Throughout the book, if you ever need to refer to another page for instructions or information, you will be told so by a  mark pointing to the page number.

Unless otherwise specified, operation buttons mentioned in the instructions refer to those located on the remote control, not those duplicated on the VCR.

Remember, you must use your VCR correctly to fully enjoy it. Please use this manual effectively. It's the surest and quickest way to unlock the full potential of your new JVC VCR.

Table Of Contents

There are two instruction manuals for the HR-IP820U—

- This one for the HR-IP820U VCR functions
- The other one for the HR-IP820U INDEX Plus+ system

Please refer to both manuals when operating the HR-IP820U.

For information on INDEX Plus+, refer to the separate INDEX Plus+ instruction manual.

Contents Of Separate INDEX Plus+ Instruction Manual

System Outline	3
INDEX Plus+ Button Functions	4
Preparing To Use INDEX Plus+	5
Receiving Broadcasts	9
Channel-Related Information	
— Practical Use of CSPG —	10
Program-Related Information (PRI)	
— Practical Use of PRI —.....	11
About Cassettes	12
Recording	13
Finding A Program	15
Revising/Erasing Directories	18
Other Convenient Functions	21
Retroactive Indexing	26
Reading A Directory From A PR Tape	29
Restoring Lost Data	30
Helpful terms and information	32
Troubleshooting	33

Getting To Know Your VCR

Front & Back Panel	4
Wireless Remote Control.....	5
Display Panel & On-Screen Mode Superimpose	6
On-Screen Menus and Displays	7

Setting Up Your VCR

Making the right connections	8
Setting your VCR's clock	9
Setting your VCR's tuner	
(if you don't use a Cable Box).....	10
Setting your VCR's tuner and Cable Box	
Controller	12
Setting Up the VCR Plus+ feature	15

▶ Playback	17
-------------------------	-----------

● Recording	23
--------------------------	-----------

🕒 Timer-Recording with VCR Plus+	26
---	-----------

🕒 Timer-Recording without VCR Plus+	28
--	-----------

👍 Special Features	31
---------------------------------	-----------

▶● Editing	32
-------------------------	-----------

? If You Have Any Questions

Before requesting service.....	36
Notes regarding	38

Precautions	39
--------------------------	-----------

About head cleaning	39
----------------------------------	-----------

Specifications	39
-----------------------------	-----------

Operaciones básicas en español	40
---	-----------

For Servicing	42
----------------------------	-----------

Warranty	43
-----------------------	-----------

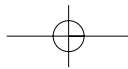

Getting To Know Your VCR

Front Panel

To open the front cover, push the left upper end where labelled "PUSH-OPEN".

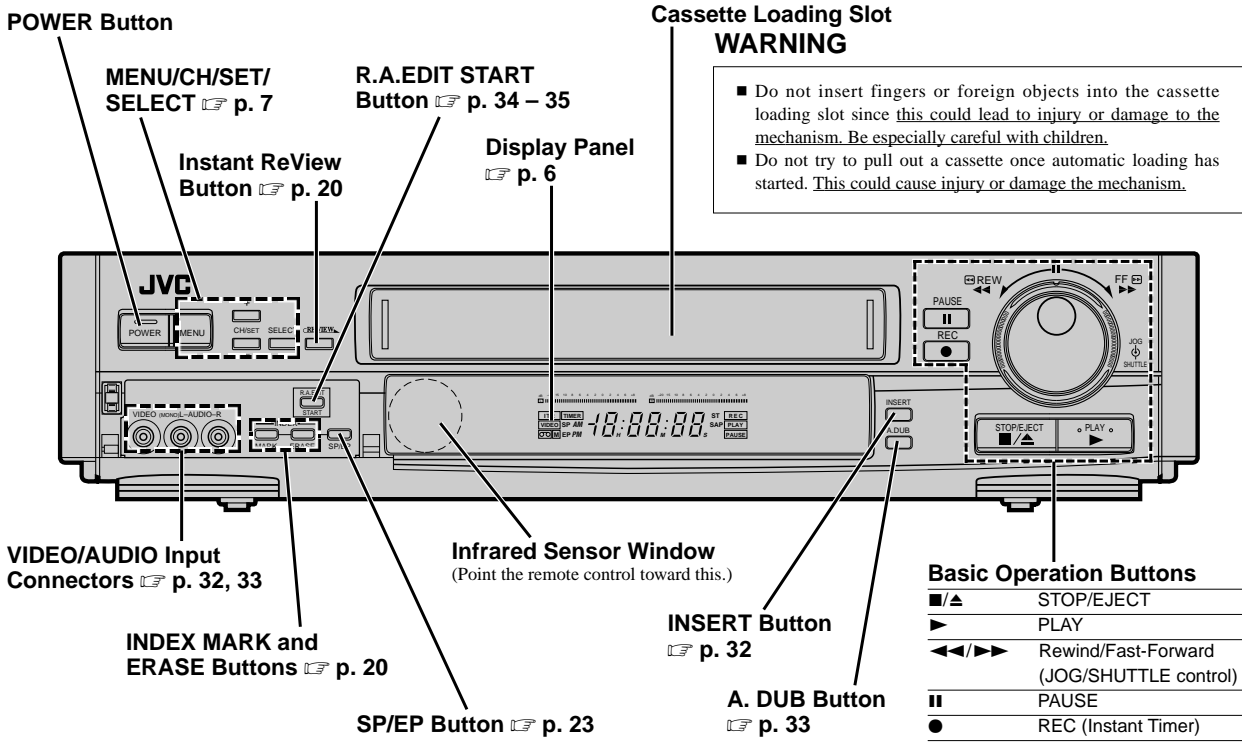

Back Panel

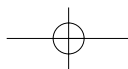
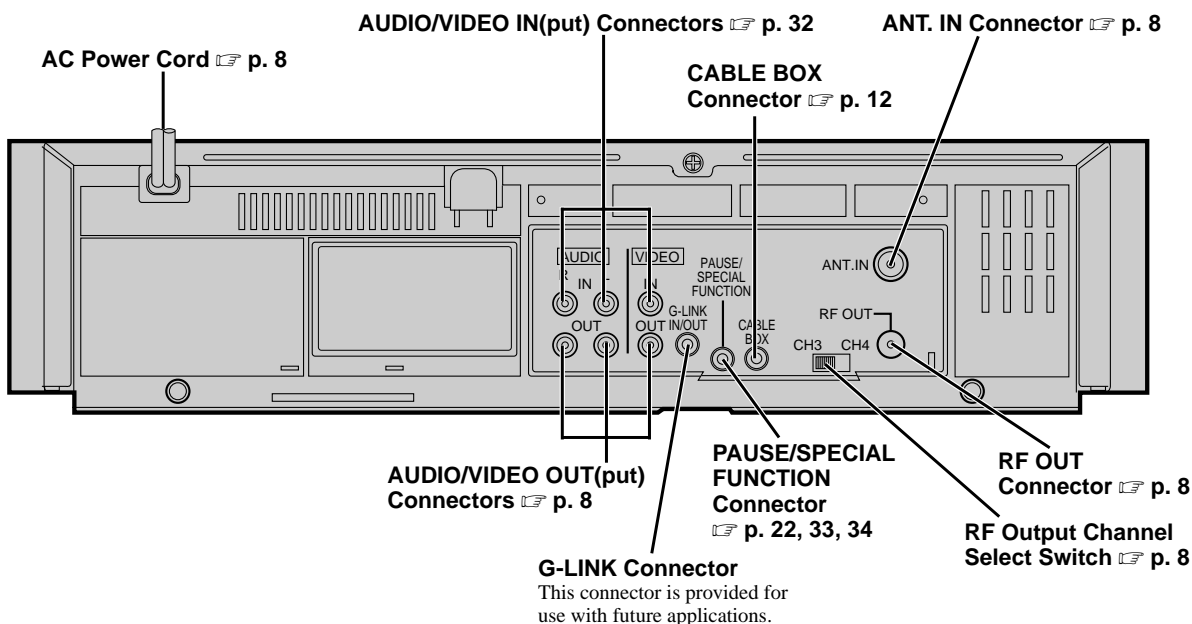

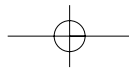

Wireless Remote Control

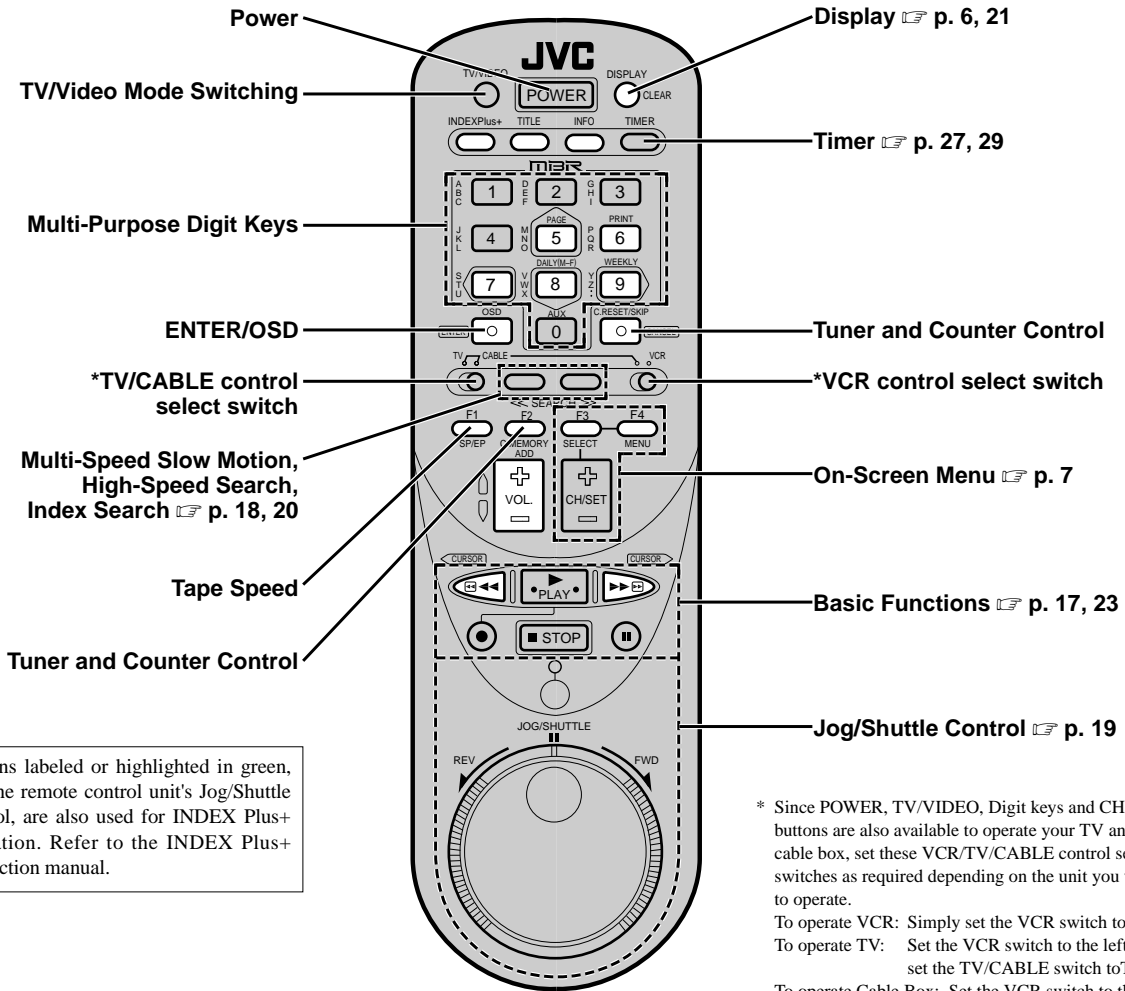

Buttons labeled or highlighted in green, and the remote control unit's Jog/Shuttle control, are also used for INDEX Plus+ operation. Refer to the INDEX Plus+ instruction manual.

* Since POWER, TV/VIDEO, Digit keys and CH +/- buttons are also available to operate your TV and/or cable box, set these VCR/TV/CABLE control select switches as required depending on the unit you want to operate.
 To operate VCR: Simply set the VCR switch to VCR.
 To operate TV: Set the VCR switch to the left and set the TV/CABLE switch to TV.
 To operate Cable Box: Set the VCR switch to the left and set the TV/CABLE switch to CABLE.

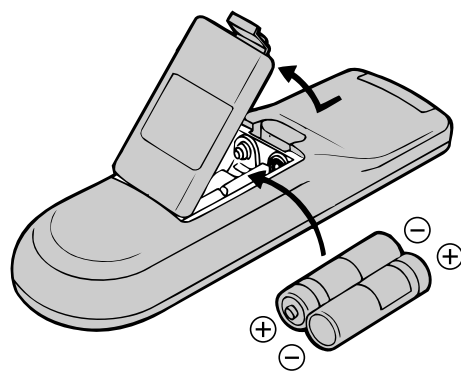

Installing Batteries

- 1 Slide the battery compartment cover in the direction of the arrow.
- 2 Insert 2 "AA"-size batteries (provided) in the correct directions.
- 3 Replace the cover.

How To Use

This remote control can operate most of your VCR's functions.

- 1 Point the remote control toward the VCR's sensor window.
- 2 Press the appropriate operation button.
 - The maximum operating distance of the remote control is about 8 m (26 ft).

This remote control can also operate various brands of TVs and Cable Boxes. For instructions, see p. 31.

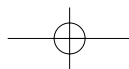

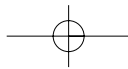

Getting To Know Your VCR (cont'd)

Display Panel

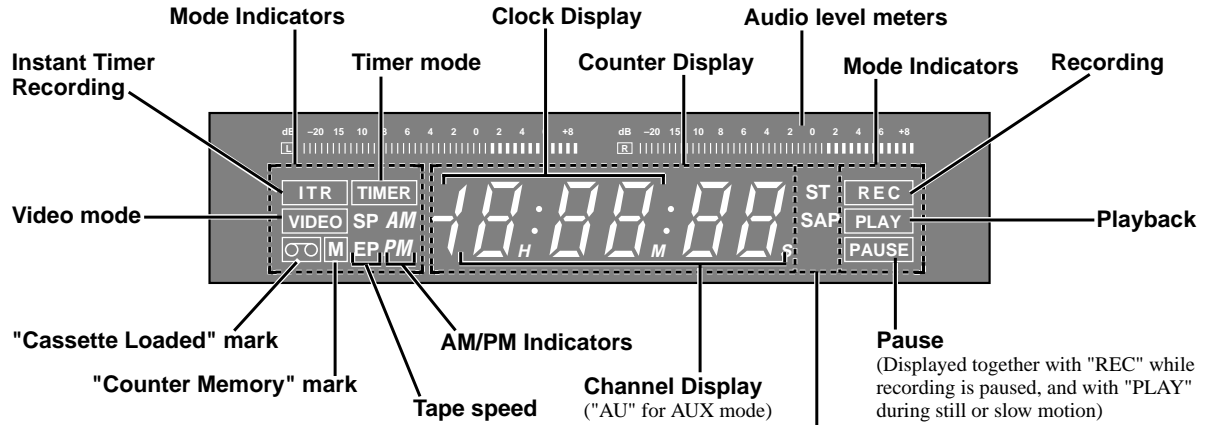

- Pressing DISPLAY lets you change the type of display: Counter, Channel*, or Clock.
- Whenever the VCR is turned off, the FDP's brightness is automatically dimmed.
- * Channel is not displayed during playback.

On-Screen Mode Superimpose

- The superimposed indication on the TV screen tells you what the VCR is doing.

Tuned-in channel or AUX(iliary) mode
When the channel is changed, the new channel is displayed on the screen for 5 seconds.

"Cassette Loaded" mark
When a cassette is loaded, the mark is displayed for 5 seconds. It blinks when the VCR's EJECT button is pushed.

Audio mode indicators

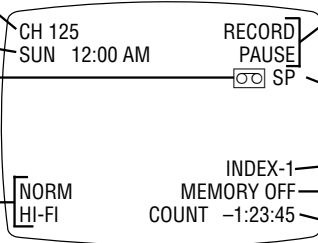

Operation mode

When the operation mode is changed, the new mode is displayed — RECORD (5 sec.), PLAY (5 sec.), FF/REW (5 sec., when engaged from Stop mode), RECORD PAUSE (for as long as Pause is engaged), and ITR **:*(5 sec.).

Tape speed indicator

INDEX indication

Counter memory on/off

Counter reading

To recall an indication

- 1 Press ENTER/OSD.
 - All indications corresponding to the current status are displayed for 5 seconds, leaving the counter information, and RECORD/PAUSE if in the Record Pause mode, on the screen.
- 2 Press ENTER/OSD again to clear the display.

To stop the on-screen indications from being shown

When you do not want to show the indications – for example when you dub a tape to another VCR (using this VCR as the player), set SUPERIMPOSE to OFF.

- 1 Press MENU, SET and SELECT to access the "SUPERIMPOSE" screen. (p. 7)
- 2 Press SET to Choose OFF.
- 3 Press MENU as many times as necessary to exit.
 - Setting is completed, and a normal TV screen is displayed.

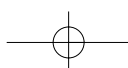
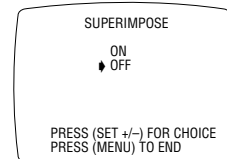

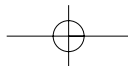

ES TAMBIEN POSIBLE LLAMAR EN PANTALLA EL MENU EN ESPAÑOL. p. 40 – 41

On-Screen Menus and Displays

■ You can set the clock, tuner, timer, and other functions using the on-screen menu. For this, the MENU, SET+/- and SELECT buttons on the VCR or remote control are used. See the instructions on the following pages for the way to use each menu.

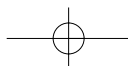
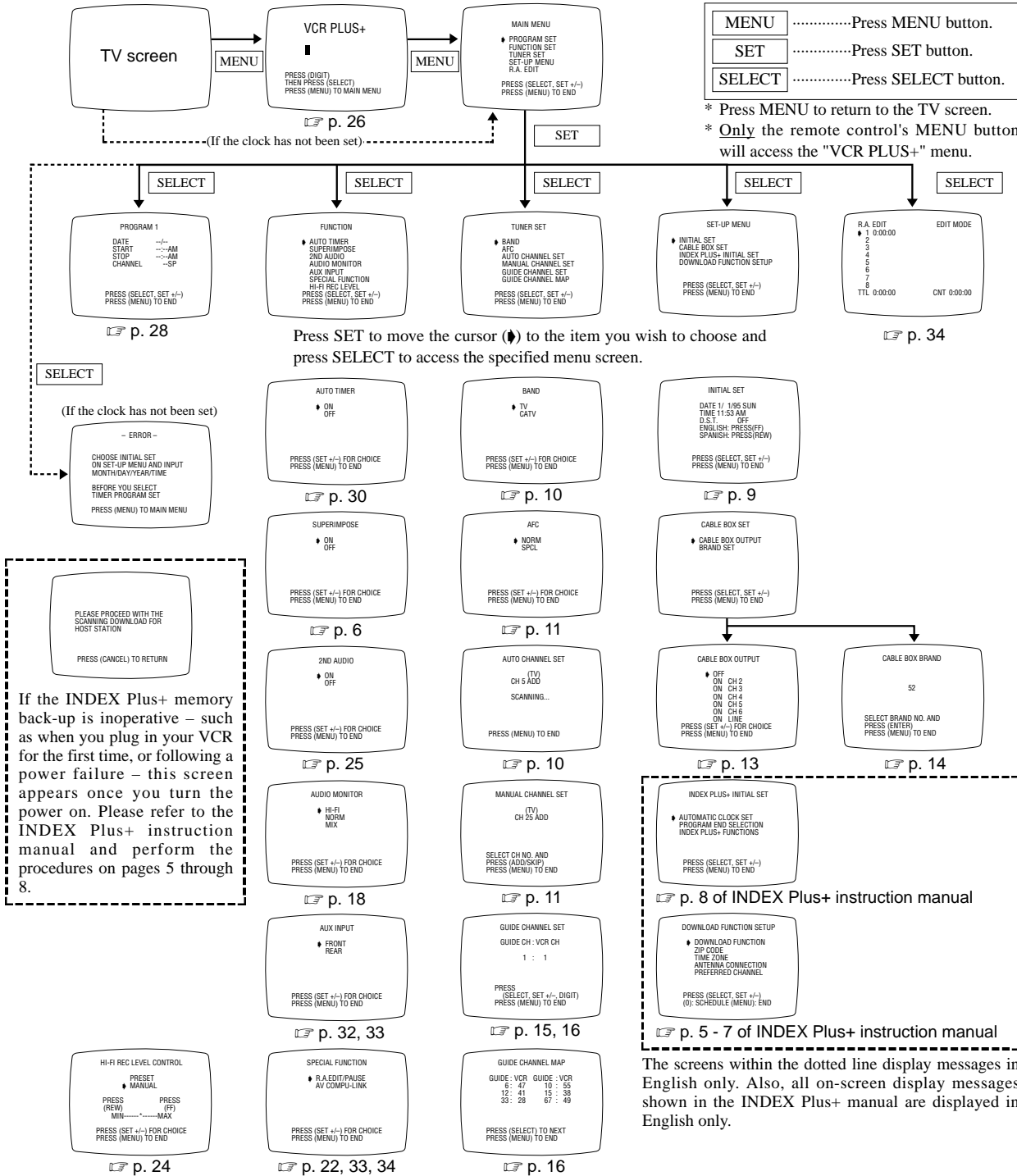

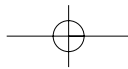

Setting Up Your VCR

Making the right connections

It's essential that your VCR be properly hooked up for proper results. Follow these steps carefully. THESE STEPS MUST BE COMPLETED BEFORE ANY VCR OPERATION CAN BE PERFORMED.

A RECORDER-TO-TV CONNECTION

RF CONNECTION

For TV sets without AV input terminals:

- 1 Disconnect the TV antenna from the TV.
- 2 Connect the TV antenna to the VCR's ANT. IN.
- 3 Connect the VCR's RF OUT to the TV's antenna terminal using the provided RF cable.

AV CONNECTION

For TV sets with AV input terminals:

- 1 Connect the antenna, VCR and TV as per "RF CONNECTION".
- 2 Connect the VCR's AUDIO OUT and VIDEO OUT to the TV's AV-IN terminals using the provided AV cable.

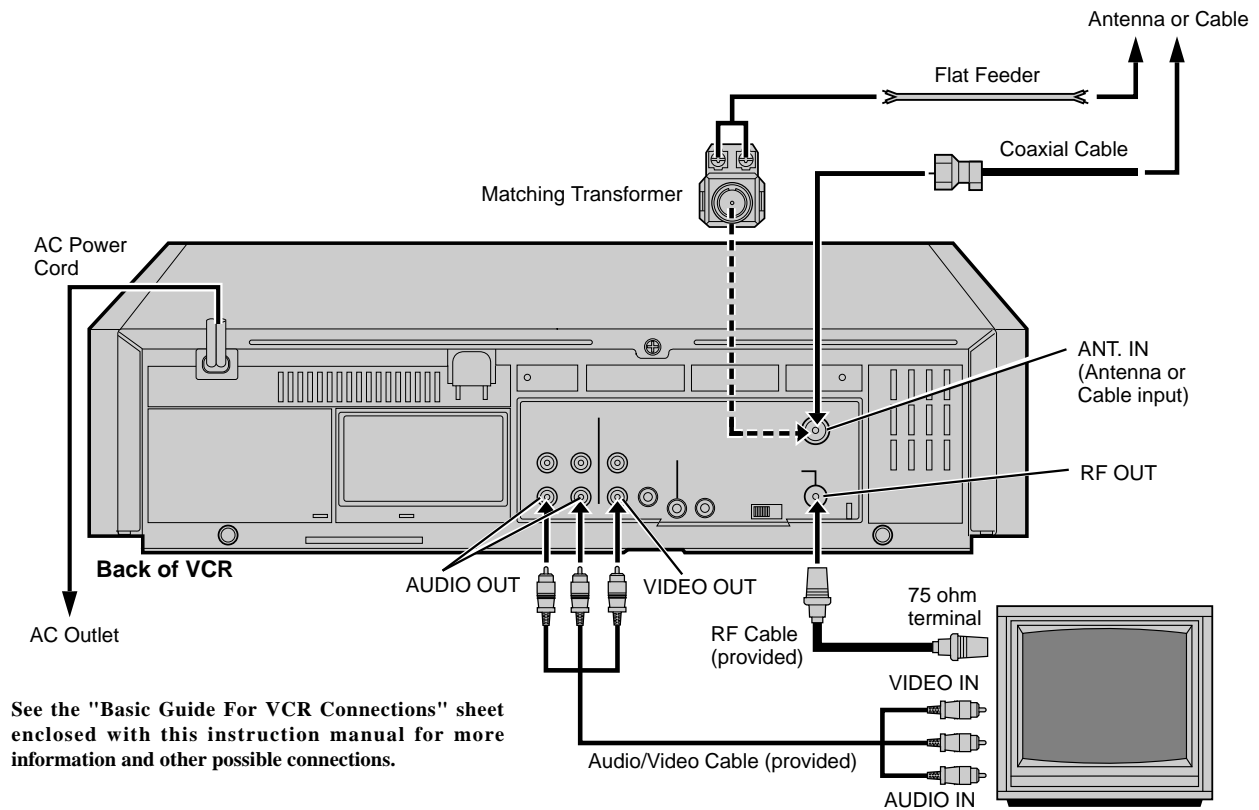

B SELECT VCR CHANNEL (3 OR 4)

With a standard RF connection, the VCR sends picture and sound signals through the connecting cable to your TV on channel 3 or 4. The VCR's switch is pre-set to CH3 prior to shipment. Set this switch to CH4 in areas where channel 3 is used for broadcasting.

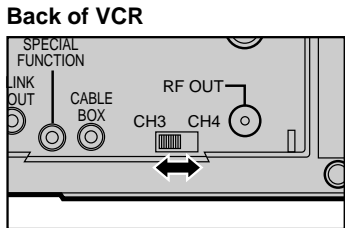

- NOTES:**
- To operate the VCR with your TV using an RF connection, it is always necessary to set your TV's channel to the one you set the VCR to in this step.
 - Even if your TV is connected using AV input connectors, it is necessary to also connect your VCR and TV using the RF cable if you ever wish to watch a program while recording another (see p. 23).

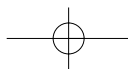

POR INSTRUCCIONES EN ESPAÑOL VEA p. 40 – 41.

Setting your VCR's clock

Since your VCR bases all of its timer recording start and stop "decisions" on the time kept by its built-in clock, accurate setting of this clock is crucial for proper timer-recording results. *When scanning the host station, the clock is automatically set (refer to page 6 of the INDEX Plus+ manual).

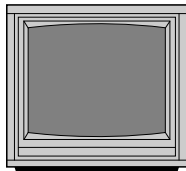

**POWER ON;
SELECT CHANNEL
3 OR 4 (OR AV MODE)**

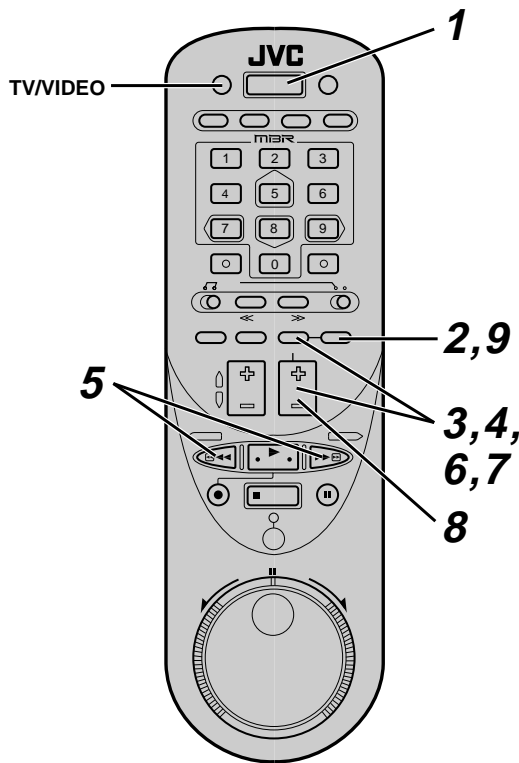
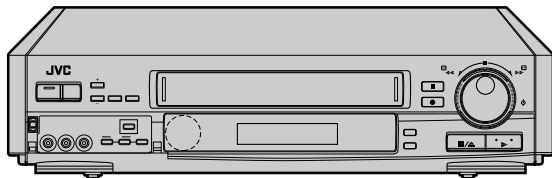

You can also use the POWER, MENU, REW, FF, SET and SELECT buttons on the VCR.

TURN ON THE VCR

- 1** Press POWER.
 - If watching on channel 3 or 4, press TV/VIDEO to select the VIDEO mode. The VCR's VIDEO indicator will light.

ACCESS THE ON-SCREEN MENU

- 2** Press MENU.
 - The Main Menu screen will appear.
 - If the VCR Plus+ screen appears press MENU again.
- 3** Press SET to move the cursor to "SET-UP MENU" and then press SELECT.
- 4** Press SET to move the cursor to "INITIAL SET", and then press SELECT.
- 5** If you want to change the on-screen language to Spanish, press REW.
 - Press FF to change back to English.
 - INDEX Plus+ on-screen display text appears in English only.

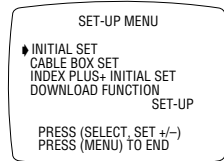

INPUT THE MONTH/DAY/YEAR/ TIME

- 6** Press SET to set the month, and then press SELECT.
- 7** Repeat step 6 to set the day, year and time (making sure that AM or PM is correct).
 - The day of the week will automatically appear.

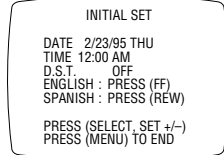

TO USE AUTO D.S.T.

- 8** If you want to take advantage of Auto D.S.T. (Daylight Saving Time) (see below), press SET to choose ON.

TO MAKE CORRECTIONS

Press SELECT so that the item you want to change blinks. Reset that item. Continue to step 9.

START THE CLOCK

- 9** Press MENU.

Auto Daylight Saving Time

Your VCR is incorporated with the D.S.T. function which automatically adjusts the clock at the start/end of Daylight Saving Time, making manual re-setting unnecessary.

When D.S.T. is set to ON:

- On the first Sunday of April, 1 minute after 1:59AM the VCR's clock is adjusted to 3:00AM.
- On the last Sunday of October, 1 minute after 1:59AM the VCR's clock is adjusted to 1:00AM.

- If you live in an area without Daylight Saving Time, keep D.S.T. OFF when setting the clock.

Setting Up Your VCR (cont'd)

POR INSTRUCCIONES EN ESPAÑOL VEA p. 40 – 41.

Setting your VCR's tuner

The Auto Set feature introduced here automatically assigns receivable channels in your area to the CHANNEL UP/DOWN buttons and skips the others so you won't have to go through any "blank" channels to get to the one you want.

FOLLOW INSTRUCTIONS ON THIS PAGE OR ON P. 12 – 14 DEPENDING ON YOUR CABLE BOX.

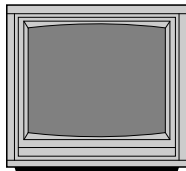

**POWER ON;
SELECT CHANNEL
3 OR 4 (OR AV MODE)**

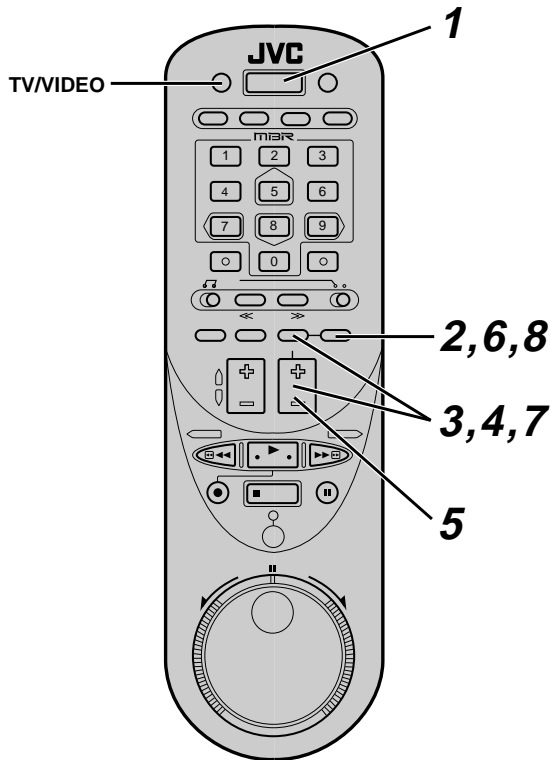
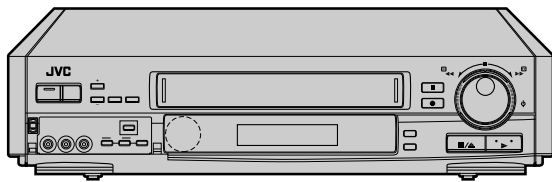

You can also use the POWER, MENU, SET and SELECT buttons on the VCR.

TURN ON THE VCR

- 1** Press POWER.
 - If watching on channel 3 or 4, press TV/VIDEO to select the VIDEO mode. The VCR's VIDEO indicator will light.

ACCESS THE ON-SCREEN MENU

- 2** Press MENU to access the Main Menu screen.
 - If the VCR Plus+ screen appears press MENU again.
- 3** Press SET to move the cursor to "TUNER SET", and then press SELECT.

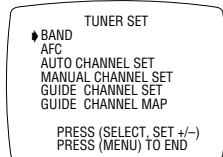

- 4** Press SET to move the cursor to "BAND", and then press SELECT.

SELECT THE BAND

- 5** Press SET to choose "TV" or "CATV".
 - The BAND select feature has 2 settings (TV and CATV). Set to TV if your antenna provides only UHF and VHF channels. Set to CATV if your antenna system is a cable TV line.

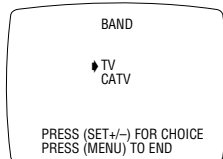

- 6** Press MENU.

START AUTO SET

- 7** Press SET to move the cursor to "AUTO CHANNEL SET", and then press SELECT.
 - Auto set is in progress and "SCANNING..." is displayed.
 - When available channels are scanned, "ADD" will be displayed on the screen.
 - When unavailable channels are skipped, "SKIP" will be displayed.
 - After completion of auto set, the lowest tuned-in channel number and "SCAN COMPLETED" are displayed.
 - If "SCAN COMPLETED — NO SIGNAL —" is displayed, check the band setting and connections, and start again. ☞ p.8.

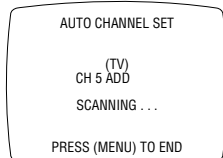
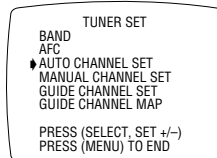

RETURN TO THE TV SCREEN

- 8** Press MENU as many times as necessary to exit.

Now go to ☞ p. 15 "Setting up the VCR Plus+ feature".

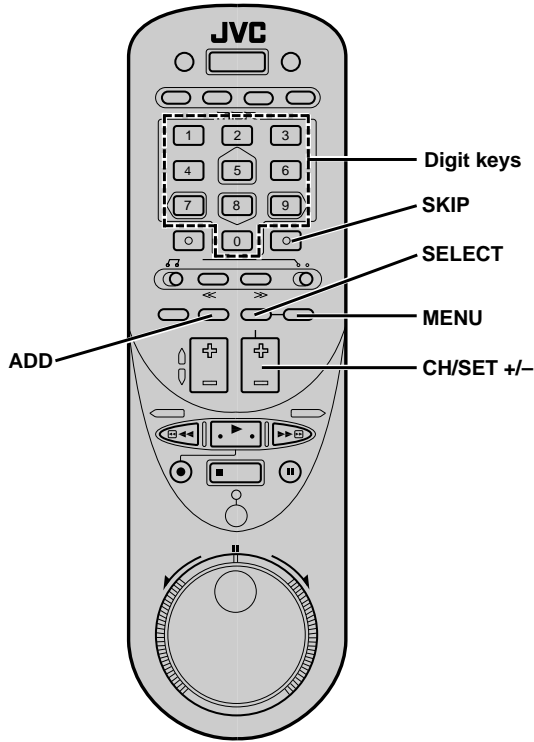
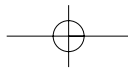

To add a "skipped" channel to your VCR's tuner

- 1 Press MENU to access the Main Menu screen.
 ■ If the VCR Plus+ screen appears press MENU again.
- 2 Press SET to move the cursor to "TUNER SET", and then press SELECT.
- 3 Press SET to move the cursor to "AFC", and then press SELECT.
- 4 Press SET to choose "SPCL".
- 5 Press MENU.
- 6 Press SET to move the cursor to "MANUAL CHANNEL SET", and then press SELECT.
- 7 Input the channel number using the Digit keys.
- 8 Press ADD to store the channel.
- 9 Specify another channel number or press MENU as many times as necessary to exit.

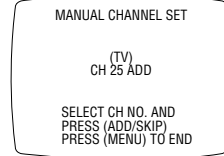

To delete an unwanted channel from your VCR's tuner

- 1 Press MENU to access the Main Menu screen.
 ■ If the VCR Plus+ screen appears press MENU again.
- 2 Press SET to move the cursor to "TUNER SET", and then press SELECT.
- 3 Press SET to move the cursor to "MANUAL CHANNEL SET", and then press SELECT.
- 4 Input the channel number using the Digit keys or the CH +/- buttons.
- 5 Press SKIP to delete the channel.
- 6 Specify another channel number or press MENU as many times as necessary to exit.

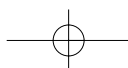
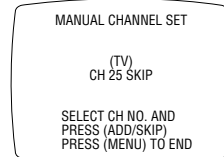

Setting Up Your VCR (cont'd)

Setting your VCR's tuner and Cable Box Controller

Follow these steps **if you use an external Cable Box** (descrambler) to receive cable stations. When properly set-up, the Multi-System Cable Box Controller will automatically switch channels on your Cable Box so you can timer-record two or more cable TV stations. It works for Cable TV shows that have been programmed using VCR Plus+ (p. 26) or On-Screen (p. 28) programming.

Suggested Locations

Attach to top of VCR with Controller's transmitter pointed towards Cable Box's remote sensor window.

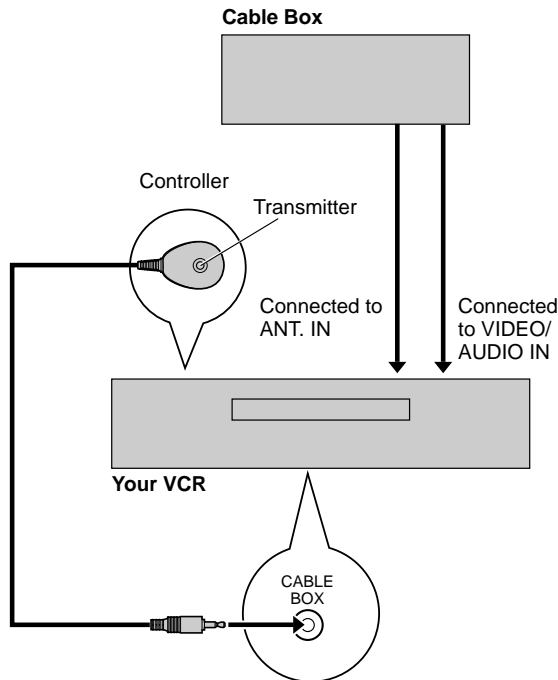
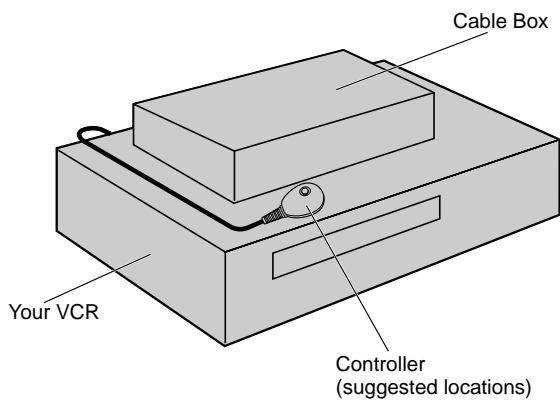

PLACE CONTROLLER IN A GOOD LOCATION

- 1** Find a location for the Controller which offers an unobstructed path to the Cable Box's remote sensor window; otherwise the Controller's infrared beam will not be able to reach and control your Cable Box.
- 2** Attach the Controller using the supplied adhesive strips.

CONNECT CABLE BOX TO VCR

If your Cable Box has VIDEO OUT/AUDIO OUT connectors...

- 3** Connect them to the VIDEO IN and AUDIO IN connectors of your VCR.

If your Cable Box does not have VIDEO OUT/AUDIO OUT connectors...

- 3** Connect the Cable Box's antenna output terminal to the ANT. IN (Antenna) terminal of your VCR.
 - Refer to the Cable Box's instruction manual for more information.

CONNECT CONTROLLER TO VCR

- 4** Connect the Cable Box Controller to your VCR's CABLE BOX terminal.

NOTE:

- About Your Cable Box:
This VCR has two separate methods to control your Cable Box. The provided Wireless Remote Control Unit can control your Cable Box. The VCR's Cable Box Controller can also control your Cable Box. The former eliminates the need for a separate Cable Box Remote Control Unit. The latter is to change your Cable Box's channel number during timer recordings. Each method must be set up separately. To set up the VCR's Remote Control Unit p. 31.

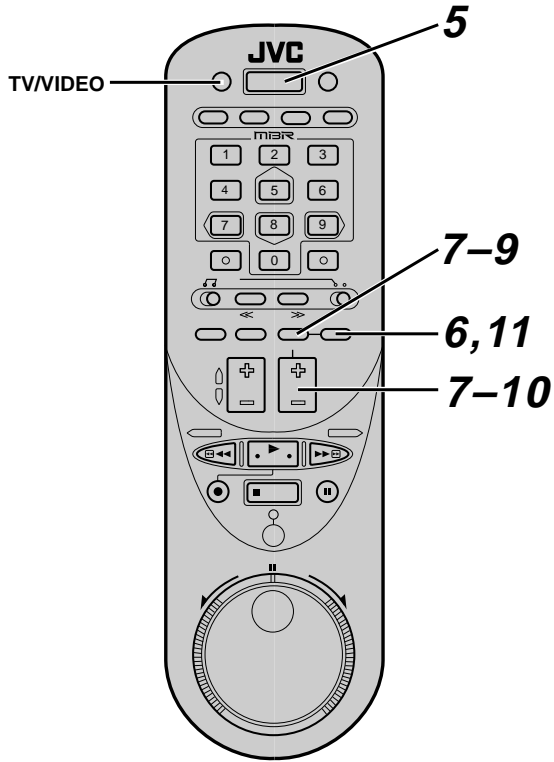

TURN ON THE VCR

- 5** Press POWER.
 ■ If watching on channel 3 or 4, press TV/VIDEO to select the VIDEO mode. The VCR's VIDEO indicator will light.

SET TO CABLE BOX'S OUTPUT CHANNEL

- 6** Press MENU until the Main Menu appears (see p.7).
7 Press SET to move the cursor to SET-UP MENU. Then press SELECT.

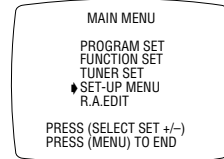

- 8** Press SET to move the cursor to CABLE BOX SET. Then press SELECT.

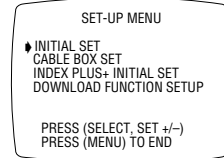

- 9** Press SET to move the cursor to CABLE BOX OUTPUT. Then press SELECT.

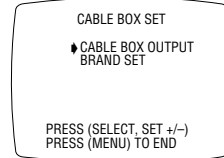

- 10** Press SET to choose the output channel number of your Cable Box (channels 2 thru 6) if it's connected to your VCR via RF connection.

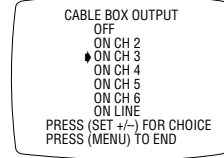

- For example, choose "ON CH3" if the Cable Box provides its output on channel 3.
- Choose "ON LINE" if the Cable Box is connected to your VCR's Audio/Video input connectors.

- 11** Press MENU.
 ■ Cable Box Set menu will appear.

(Continued on next page.)

Setting Up Your VCR (cont'd)

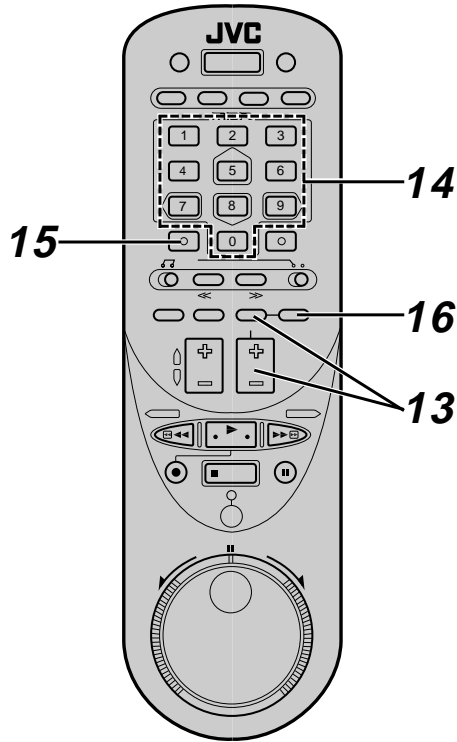

NOTES:

- Although the provided Cable Box Controller is compatible with many different cable box brands, it is possible that it will not work with your cable box.
- If your cable box does not respond to any of the codes, your VCR is not able to change its channels during timer recordings. For this type of cable box, always remember to leave it turned on and tuned to the channel you want to record before the timer recording is programmed to start.
Please contact your cable company about the possibility of exchanging your current cable box with one that is compatible with the VCR.
- The VCR can change the Cable Box channel selection through the Cable Box Controller only during timer recording.
- If your cable box cannot be controlled by a remote control, your VCR will not be able to change its channels during timer recording. For this type of cable box, turn it on and select the channel you want to record before the timer recording is programmed to start.
- If you are unable to set the cable box controller please contact JVC toll free at 1-800-252-5722.

SET CABLE BOX BRAND

- 12** Turn on the Cable Box's power.
 - Select a channel other than 9 on your Cable Box.
- 13** Press SET to move the cursor to BRAND SET. Then press SELECT.
- 14** Press the Digit keys corresponding to the code number for your Cable Box's brand. (See list below.)
- 15** Press ENTER.
 - If Cable Box's channel changes to "9", setting is completed.
 - If the brand has more than one code number listed, repeat steps 14 -15 until you reach the code that changes your Cable Box's channel.
 - Perhaps your cable box will respond to a new code number not yet published in the list. Try entering all code numbers from 1 to 101.
- 16** Press MENU as many times as necessary to exit.

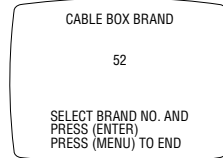

- Now go to p. 15 "Setting up the VCR Plus+ feature".
- To change cable channels or turn on/off your cable box using the VCR's remote control, p. 31.

CABLE BOX BRAND LIST

BRAND	CODE	BRAND	CODE
ARCHER	52, 53, 54, 85, 86	RCA	25, 26, 27
CABLEVIEW	85, 86	REGAL	78, 79, 80
CITIZEN	85, 86	REGENCY	51
CURTIS	13, 14, 15, 16	SAMSUNG	74, 75, 76
DIAMOND	52, 53, 54	SCIENTIFIC ATLANTA	13, 14, 15, 16
EAGLE	30, 31, 32, 33, 34, 35, 36, 37	SL MARX	74, 75, 76
EASTERN	51	SPRUCER	25, 26, 27
GC BRAND	85, 86	STARGATE	74, 75, 76, 85, 86
GEMINI	55, 56	SYLVANIA	70
GENERAL ELECTRIC	67	TEKNIKA	68, 69
GENERAL INSTRUMENTS	1, 2, 3, 4, 5, 6, 101	TELECAPTION	100
HAMLIN	23, 24	TELEVIEW	74, 75, 76
JERROLD	1, 2, 3, 4, 5, 6, 62, 63, 64, 65, 101	TEXSCAN	28, 29
MACOM, HITACHI	57, 58, 59	TOCOM	62, 63, 64, 65, 66
MAGNAVOX	43, 44, 45, 46, 47, 48, 49	UNIKA	52, 53, 54, 85, 86
MOVIE TIME	71, 72, 73	UNIVERSAL	81, 82, 83, 84
NSC	71, 72, 73	VIDEOWAY	9, 10, 11, 12
OAK	17, 18, 19, 20, 21, 22	VID TECH	89
PANASONIC	25, 26, 27	VIDTER	89
PHILIPS	38, 39, 40, 41, 42	VIEWSTAR	30, 31, 32, 33, 34, 35, 36, 37
PIONEER	7, 8	ZENITH	9, 10, 11, 12
PULSER	85, 86		

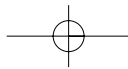

Setting up the VCR Plus+ feature

Depending on the broadcast stations that are receivable in your area, or the cable stations offered by your cable supplier, you may have to make certain changes in your VCR's "Guide Channel Set" menu to get proper results. Please read on and find out what you need (and don't need) to do. (After host station scanning, Guide Channel Setting is accomplished automatically, so there's no need for you to do it manually. Refer to page 6 of the INDEX Plus+ manual).

Make sure that you have already...

- set the VCR's clock
- set the VCR's tuner.
- set the Cable Box Controller (☞ p. 12) if using a Cable Box.

(If NOT using Cable Box)

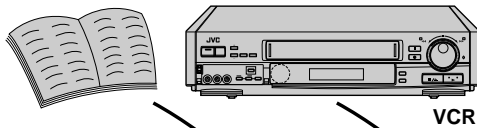

Example of non-matching channels

Broadcast Station	VCR Plus+ Assigned Guide Channel	The channel your VCR receives the station on
WNYB (TBN)	67	49
WSBK Boston, MA	15	38
WXTV Paterson, NJ	12	41
WNJU (Ind.)	6	47
WEDW Bridgeport, CT	14	49
WLIG Riverhead	10	55
WFXV (FOX)	33	28

(If using Cable Box)

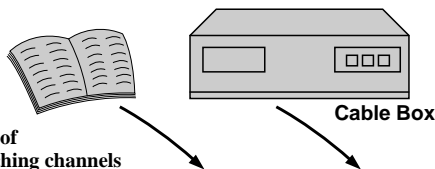

Example of non-matching channels

Cable Station	VCR Plus+ Assigned Guide Channel	The channel your Cable Box receives the station on
WNJU (Ind.)	6	8
WLIW (PBS)	21	34
Music Television	48	20
Cable News Network	42	27
Home Box Office	33	28
Cinemax	45	29

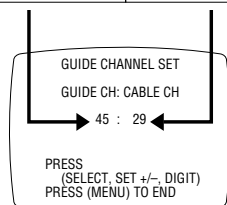

Then...

COMPARE CHANNEL NUMBERS

Most TV listings will have a chart indicating the "Guide Channel" number that each TV station has been assigned for purposes of VCR Plus+ programming. Check in your TV listing and see whether that number is the same as the channel number you receive that station on with your VCR or Cable Box.*

If the numbers match, you don't have to do anything. You can go directly to "Timer-Recording with VCR Plus+" p. 26.

If there are stations where the numbers are different, and you want to be able to timer-record them, you will have to "tell" the VCR about the mismatch. Go to step 1.

If there are stations where the numbers are different, but you don't want to timer-record them, you can go directly to "Timer-Recording with VCR Plus+" p. 26.

* SPECIAL NOTE FOR CABLE SUBSCRIBERS

- In many instances, cable TV stations have VCR Plus+ Guide Channel numbers that DO NOT match the actual channel number the station is received on. Check your TV listing, or check with your cable supplier for details.
- In many instances, normal broadcast TV stations can be viewed on cable. Check your TV listing, or check with your cable supplier for details.

TURN ON THE VCR

- 1 If the VCR is off, press POWER to turn it on.
 - If watching on channel 3 or 4, press TV/VIDEO to select the video mode. The VCR's VIDEO indicator will light.

ACCESS THE ON-SCREEN MENU

- 2 Press MENU, SET and SELECT as many times as necessary to access the "TUNER SET" screen. (☞ p.7)
- 3 Press SET to move the cursor to "GUIDE CHANNEL SET", and then press SELECT.
 - The Guide Channel Set screen will appear.
 - If you have set the Cable Box Controller feature CABLE CH is displayed instead of VCR CH.

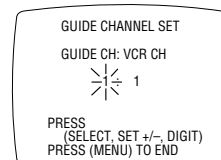
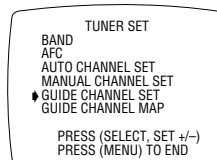

(Continued on next page.)

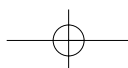

Setting Up Your VCR (cont'd)

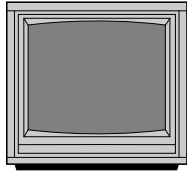

**POWER ON;
SELECT CHANNEL
3 OR 4 (OR AV MODE)**

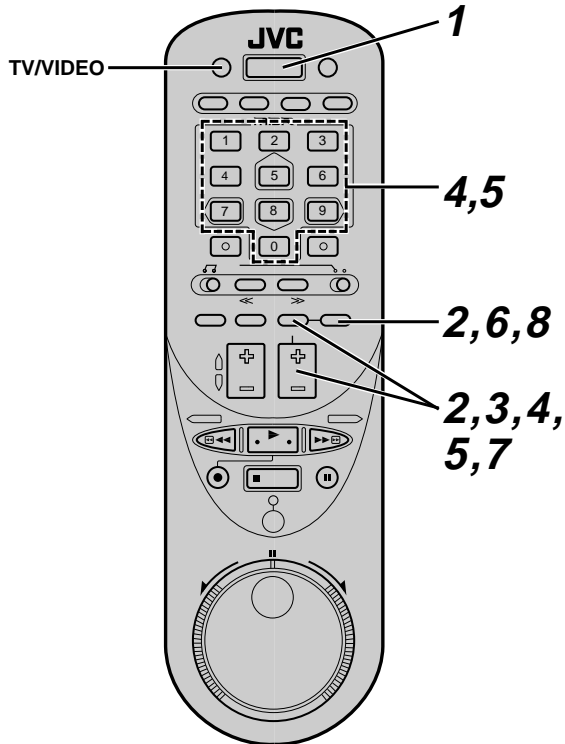
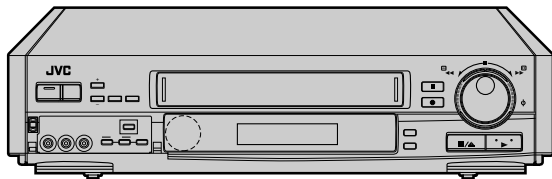

NOTES:

- After host station scanning (refer to page 6 of the INDEX Plus+ instruction manual), when Guide Channel Setting is taking place, changes or additions are also performed if you pressed 1 in step 8.
- If you pressed 2 in step 8 but later decide you want automatic updating, you have to re-perform host station scanning (refer to page 6 of the INDEX Plus+ instruction manual).

INPUT THE GUIDE CHANNEL

- 4** Press SET or the Digit keys to input the Guide Channel number (as shown in TV listing or this manual), and then press SELECT.

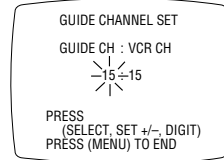

INPUT THE RECEIVING CHANNEL

If you don't use an external Cable Box . . .

- 5** Press SET or the Digit keys to input the channel number your VCR receives the station on, and then press SELECT.

- If there are other GUIDE CH numbers which don't match with the VCR CH numbers, input the changes by repeating steps 4 – 5.

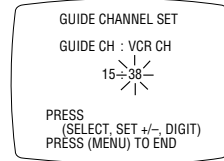

If you use an external Cable Box . . .

- 5** Press SET or the Digit keys to input the channel number your Cable Box receives the station on, and then press SELECT.

- If there are other GUIDE CH numbers which don't match with the CABLE CH numbers, input the changes by repeating steps 4 – 5.

CHECK THE GUIDE CHANNEL MAP

- 6** Press MENU once to go back to the Tuner Set menu.

- 7** Press SET to move the cursor to "GUIDE CHANNEL MAP", and then press SELECT.

- A screen with GUIDE CH numbers (in ascending order) with their corresponding VCR CH numbers will be displayed. Check to make sure your entries are correct.

- If there are more than 10 entries, press SELECT to display the 11th and higher entries.

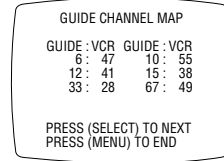
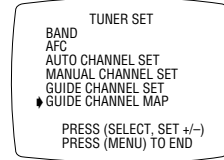

RETURN TO THE TV SCREEN

- 8** Press MENU as many times as necessary to exit.

- After host station scanning, if Guide Channel Setting is completed automatically, a screen like the one to the right appears prior to the normal screen.

- You can choose whether or not the Guide Channel will automatically be updated when changes or additions occur. To select automatic updating, press 1. To make changes manually, press 2.

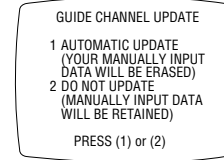

▶ Playback

POR INSTRUCCIONES EN ESPAÑOL VEA p. 40 – 41.

The easiest, most basic operation possible with your VCR is tape playback. Previously-recorded signals on a video tape are read by your VCR and displayed on your TV just like a TV program.

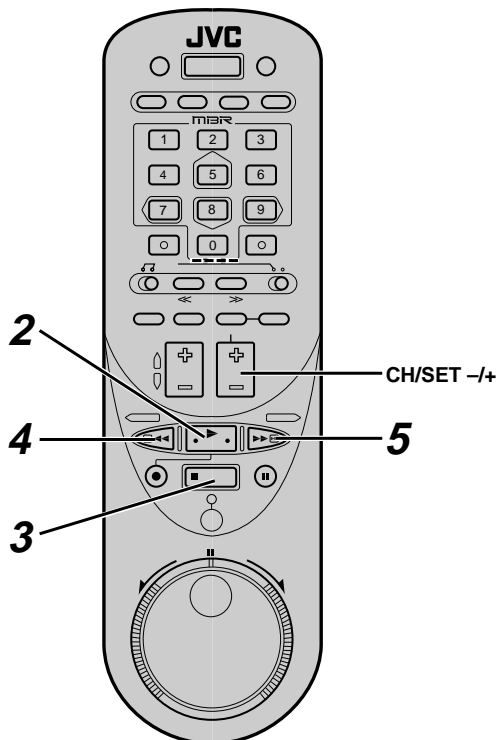
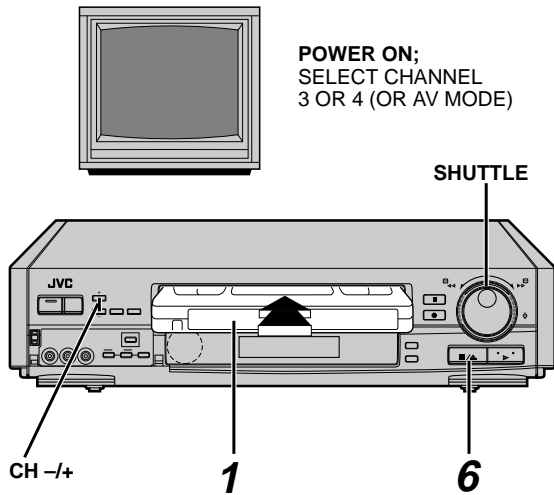

LOAD A CASSETTE

- 1** Insert a cassette with its window side up, and label side facing you. Press gradually on the middle of the cassette until the VCR pulls the cassette in.
 - The VCR power will come on automatically.
 - "READING TAPE#..." will appear on the screen unless INDEX Plus+ functions are set to OFF. (See p.12 of INDEX Plus+ instruction manual.)
 - The counter will be reset to "0H 00M 00s" automatically.
 - If the safety tab on the cassette is absent, playback will start automatically.

TO START PLAYBACK

- 2** Press PLAY.

TO STOP PLAYBACK

- 3** Press STOP.

TO REWIND OR FAST-FORWARD

- 4** Press REW to rewind the tape.
- 5** Press FF to fast-forward the tape.
 - Press STOP to stop the tape.
 - To rewind or fast-forward the tape using the VCR's control, turn the SHUTTLE ring fully to the corresponding direction, and release it.

TO EJECT THE TAPE

- 6** Press the VCR's STOP/EJECT button again.

To adjust tracking manually

This overrides your VCR's automatic tracking.

During Playback...

- 1** Press the VCR's CH(annel) +/- buttons simultaneously to cancel auto tracking.
 - The remote control's CH +/- cannot be used for this purpose.
- 2** Press CH + or - to adjust tracking.
 - Press the VCR's CH +/- simultaneously to return to automatic tracking.

During Slow...

- 1** Simply press CH + or - to adjust tracking.

▶ Playback (cont'd)

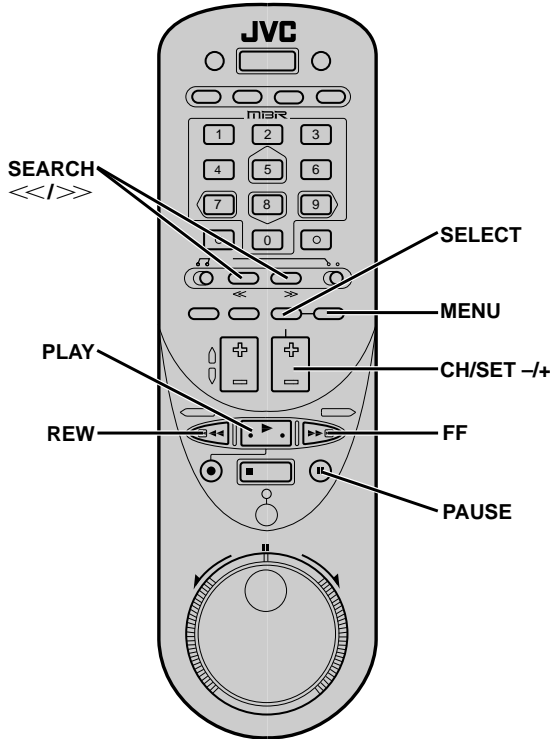

To view a still picture

During Playback...

- 1 Press PAUSE to view a still picture.
 - If there is vertical picture jitter, press CH - or + (on the VCR or remote control) to make the picture more stable.
- 2 To advance the picture frame by frame, press PAUSE again.
 - For frame-by-frame playback in the forward or reverse direction, press SEARCH << or >> (on the remote control) in the corresponding direction while in the still picture mode.
- 3 Press PLAY to resume normal playback.

To view a slow, reverse, reverse slow or fast-motion picture

During Playback...

- 1 Press the SEARCH << or >> button (on the remote control). Tape speed will change in the corresponding direction.
 - To increase the speed in the forward direction, press the >> button.
 - To decrease the speed in the forward direction, press the << button.
 - To play in reverse slow motion and in reverse play mode, continue to press the << button after selecting all the forward slow motion modes.
 - For forward slow motion playback, press PAUSE for more than 2 seconds while in the still picture mode.
- 2 Press PLAY to resume normal playback.

Or...

During Playback...

- 1 Press FF for forward fast-motion, or REW for reverse fast-motion.
- 2 Press PLAY to resume normal playback.
 - For short searches, keep FF or REW pressed for more than 2 seconds. When released, normal playback will continue.

To select the soundtrack

Your VCR is capable of recording two soundtracks (Hi-Fi and NORMAL) simultaneously, and playing back the selected soundtrack or two together.

During Playback or Stop:

- 1 Press MENU, SET, and SELECT as many times as necessary to access the AUDIO MONITOR screen. (p. 7).
- 2 Press SET to choose "HI-FI", "NORM", or "MIX".
 - HI-FI to listen to the Hi-Fi soundtrack.
 - NORM to listen to the normal soundtrack.
 - MIX to listen to both soundtracks combined. Select this setting when playing back edited tapes with insert edits or dubbed audio made on an appropriately equipped VCR.
 - Normal audio will be outputted regardless of the playback audio monitor selection if Hi-Fi audio is not present on the tape.
- 3 Press MENU as many times as necessary to exit.

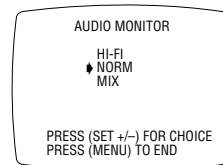

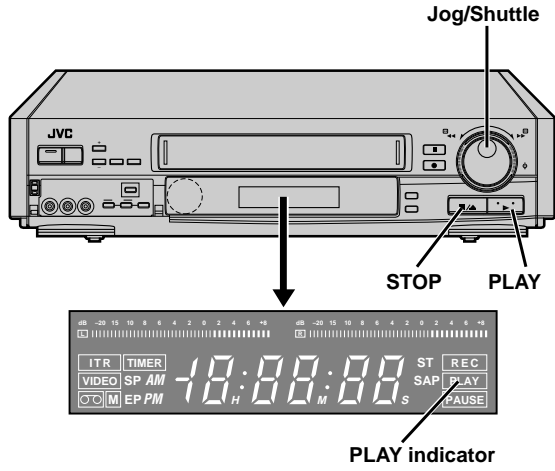
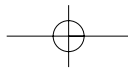

To view jog/shuttle special effects

You can view pictures in slow to fast motion, or frame-by-frame.

During Still or Playback...

- 1 Press JOG/SHUTTLE.
 - The LED indicator will light.
 - Not necessary when using the VCR's Jog/Shuttle.
- 2 Turn the outer ring (Shuttle) to the right for forward slow motion and search.
 - Release the Shuttle for a still picture.
 - For fast-forward with a visible picture, turn the VCR's Shuttle all the way to the right and release it within 1 second.
- 3 Turn the outer ring (Shuttle) to the left for reverse slow motion and search.
 - Release the Shuttle for a still picture.
 - For rewind with a visible picture, turn the VCR's Shuttle all the way to the left and release it within 1 second.

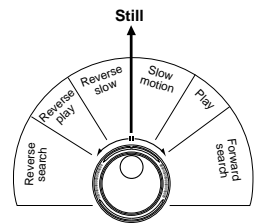

During Still or Playback...

- 1 Press JOG/SHUTTLE.
 - The LED indicator will light.
 - Not necessary when using the VCR's Jog/Shuttle.
- 2 Rotate the inner dial (Jog) clockwise or counterclockwise for jog control. The tape moves frame-by-frame at the speed with which the dial is rotated, in the direction the dial is rotated. (By rotating the Jog dial counterclockwise at 2 revolutions per second or faster, reverse play is possible.)
To resume normal playback, press the PLAY button.

Repeat Playback

To play the whole tape repeatedly.

During Playback...

- 1 Press PLAY for more than 5 seconds, and release.
 - The "PLAY" indicator on the VCR panel will blink slowly.
 - The tape will be played 20 times automatically, and then stop.
 - To stop repeated playback at any time, press STOP.

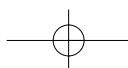
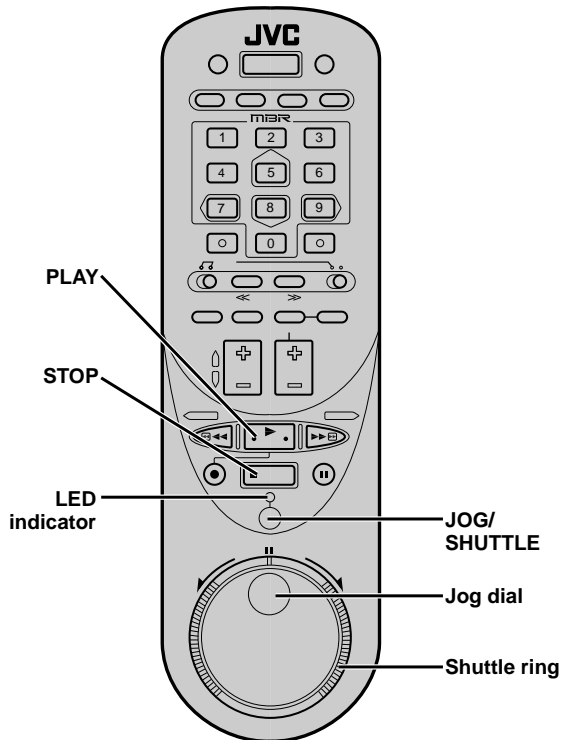

▶ Playback (cont'd)

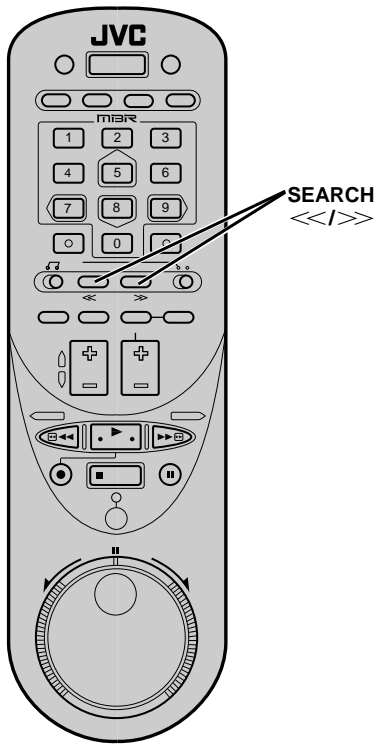
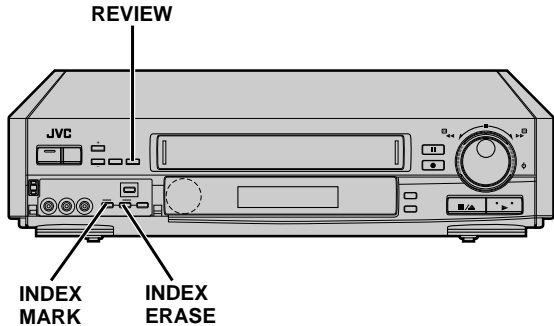

Instant ReView

Simply by pressing a single button, the VCR power comes on, rewinds, and begins playback of the last recording. This makes it easier to "review" the program you have timer-recorded.

When the VCR power is off:

- 1 Press REVIEW.
 - After the VCR power comes on, the tape will be rewound to the beginning of the last recording (where the index code is placed) and playback will start automatically.
 - To playback a recording located 2 index codes away, press REVIEW twice. You can access any one of up to 9 index codes.
 - ReView is not possible while the VCR is in the Timer mode.
 - The VCR's REVIEW button lights when timer-recording is finished, and blinks while the tape is being rewound.

Index Search

Index codes are electronic "bookmarks" which are automatically placed on the tape whenever recording is started. Index Search automatically seeks out these index codes so you can easily find the beginning of a recording (up to 9 index codes away in either direction).

During Stop....

- 1 Press SEARCH << or >>. "INDEX -1" or "INDEX 1" will be displayed and search will begin in the corresponding direction.
- 2 If you wish to access index codes 2 through 9, press SEARCH << or >> repeatedly until the correct index number is displayed.
 - When the specified index code is found, playback will start automatically.

Manual Index Mark/Erase

TO MARK AN INDEX CODE

During Playback...

- 1 Press INDEX MARK.
 - The VCR will mark an index code at that location.
 - "MARK" blinks while an index code is being marked.

TO ERASE AN INDEX CODE

During Playback or Still...

- 1 Press INDEX ERASE.
 - The VCR will fast-forward to the nearest index code and erase it. Playback continues after the index code is erased.
 - "ERASE" blinks while an index code is being erased.

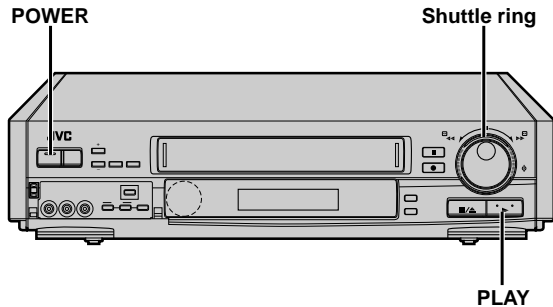
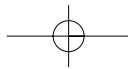

Counter Reset

To reset the tape counter to zero.

- 1 Press C. RESET.
 - Pressing DISPLAY repeatedly changes the VCR's displayed indication. (Counter reading → Channel* → Clock time).
- *Channel is not displayed during playback.

Counter Memory

To return to tape position zero.

During Playback...

- 1 Press C. RESET at a point you wish to locate later.
 - The counter will read "0h 00m 00s".
- 2 Press C. MEMORY.
 - Counter Memory mark is displayed.
- 3 When you wish to return to that point, press STOP and then press REW.
 - The tape will rewind and stop at about "0h 00m 00s" automatically.
- 4 To cancel the Counter Memory mode, press C. MEMORY.

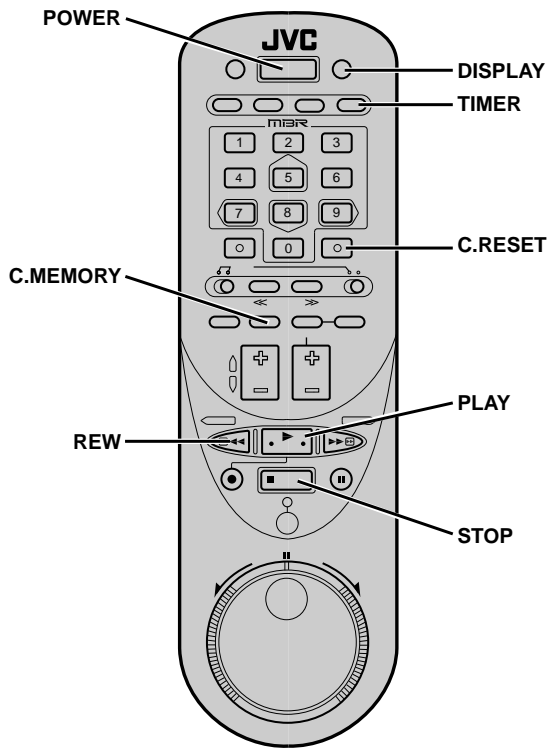

Next-Function Memory

You can "tell" the VCR what to do immediately after rewinding.

During Stop:

For automatic start of playback after the tape is rewind...

- 1 Press REW.
- 2 Press PLAY within 2 seconds.

For automatic power off after the tape is rewind...

- 1 Press REW.
- 2 Press POWER within 2 seconds.

For automatic timer standby after the tape is rewind...

- 1 Press REW.
- 2 Press TIMER within 2 seconds.

■ To do the above using the VCR's controls:

During Stop, turn the Shuttle all the way to the left and release it instead of pressing REW, and then press PLAY or POWER within 2 seconds.

- If you want the "next function" to automatically start when the counter reads "0h 00m 00s" (instead of at the beginning of the tape), press C. MEMORY so that the counter memory "M" mark appears on the VCR display panel before pressing REW or FF.

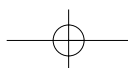

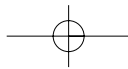

▶ Playback (cont'd)

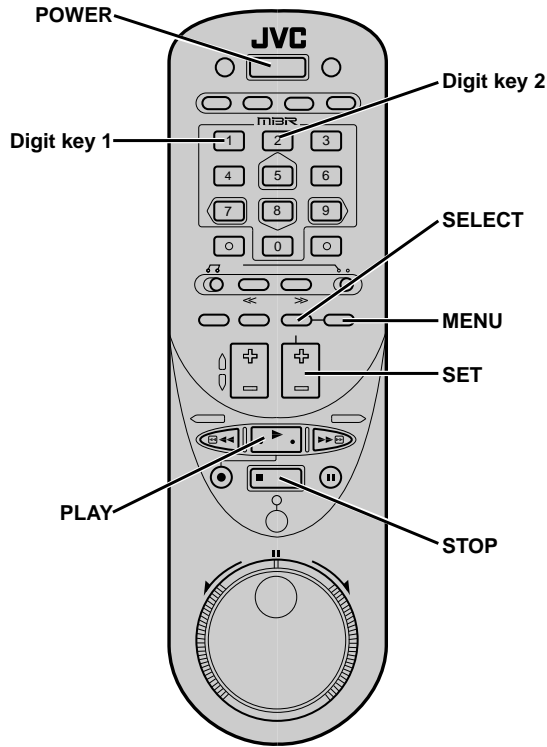

To control two JVC VCRs

The remote control is capable of controlling two JVC VCRs independently; one set to respond to your remote control's A code control signals and another set to respond to B code control signals. The remote control is preset to send A code signals because your VCR is initially set to respond to A code signals. You can easily modify your VCR to respond to B code signals.

- 1 Hold down the remote control's STOP button.
Press the digit key "2". Release the STOP button.
- 2 Unplug the VCR's power cord from the AC outlet and then plug it back in again. Do not use other remote controls at this stage.
- 3 Turn the VCR power on using the remote control's POWER button. The VCR will now respond only to B code signals.
 - To set the VCR back to respond to A code signals, repeat the same procedure as shown above except pressing Digit key "1" instead of "2" in step 2.
 - If you want to operate two JVC VCRs independently which are set to respond to either A or B code signals, set the remote control to the code corresponding to the VCR you want to operate:
 - To operate a VCR set to A code, while holding down the remote control's STOP button, press the Digit key "1".
 - To operate a VCR set to B code, while holding down the remote control's STOP button, press the Digit key "2".

Example

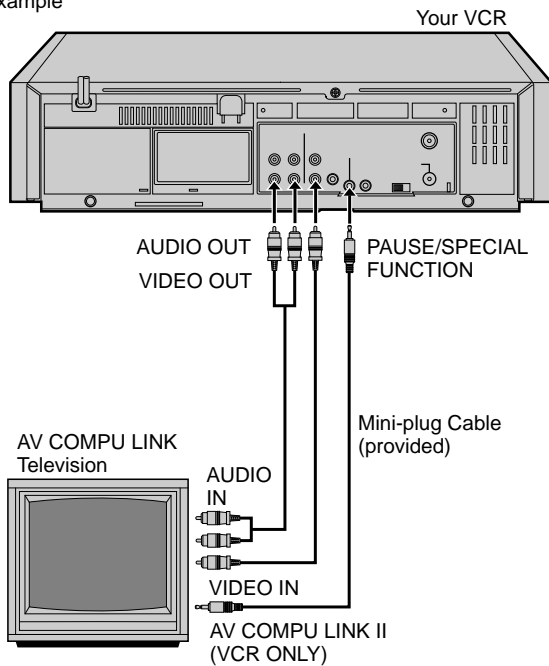

AV COMPU LINK Playback

Your VCR is compatible with JVC's AV COMPU LINK components which include amplifiers (or receivers) and televisions.

PREPARATION

- 1 Connect your VCR to an AV COMPU LINK amplifier and/or an AV COMPU LINK television as illustrated.
- 2 Press MENU, SET, and SELECT as many times as necessary to access the SPECIAL FUNCTION screen.
(☞ p. 7)
- 3 Press SET to choose "AV COMPU-LINK".
- 4 Press MENU as many times as necessary to exit.

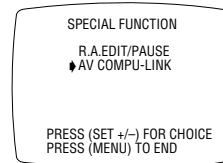

OPERATION

- AV COMPU LINK video playback is as easy as this:
- Simply load a cassette in your VCR and press PLAY. (If the cassette's safety tab has been removed, it is not necessary to press play.) The TV (and amplifier) turn on automatically and the TV's mode is automatically set to VIDEO; you're ready to watch!
 - Connection varies according to the type of TV. Please read your TV's instruction manual when making TV connection.

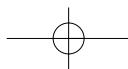

Recording

POR INSTRUCCIONES EN ESPAÑOL VEA p. 40 – 41.

TV signals being received by the VCR's built-in tuner can be recorded onto a video tape. This is realtime video recording.

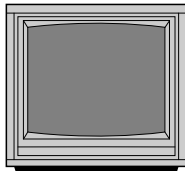

**POWER ON;
SELECT CHANNEL
3 OR 4 (OR AV MODE)**

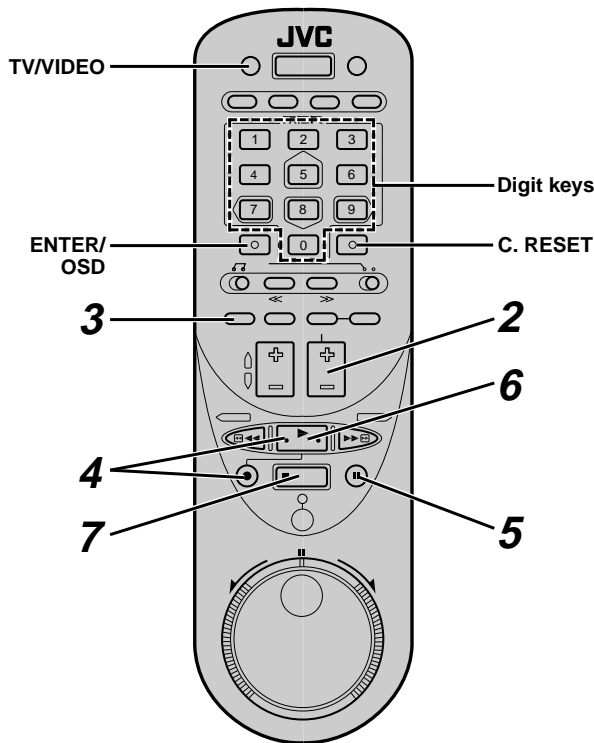
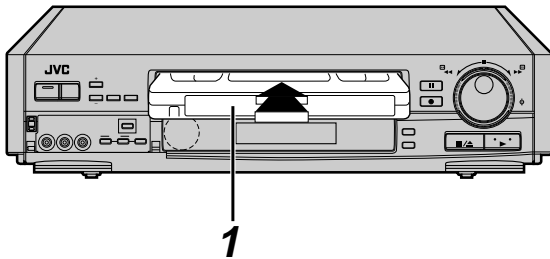

LOAD A CASSETTE

- 1** Insert a cassette with the safety tab present.
 - The VCR power will come on automatically.
 - "READING TAPE#..." will appear on the screen unless INDEX Plus+ functions are set to OFF. (See p. 12 of INDEX Plus+ instruction manual.)
 - If watching on channel 3 or 4 be sure that the VIDEO indicator is lit. If the indicator is not lit, press TV/VIDEO so that it lights.

CHOOSE A PROGRAM

- 2** Press CH(annel) +/- (or the digit keys followed by ENTER) to select the channel you wish to record.
 - Even if you don't press ENTER, the channel will automatically change in about 2 seconds.

SET THE TAPE SPEED

- 3** Press SP/EP.

TO START RECORDING

- 4** Press REC and PLAY simultaneously.
 - If "PLEASE ENTER THE CABLE BOX CH NUMBER" appears on the screen, input the cable box channel using the digit keys, then press ENTER.
 - If "TAPE# CAN NOT BE READ" appears on the screen, refer to page 13 of INDEX Plus+ instruction manual.

TO PAUSE RECORDING

- 5** Press PAUSE.
- 6** Press PLAY to resume recording.

TO STOP RECORDING

- 7** Press STOP.

To watch a program while recording another

During Recording...

- 1** Press TV/VIDEO. The VCR's VIDEO indicator and the TV broadcast being recorded will disappear.
- 2** Use the channel controls on the TV to select the other channel you wish to view.
 - The program selected with the TV channel controls will appear on the TV screen while the one selected with the VCR channel controls will be recorded on the tape.

To display the elapsed recording time

Before starting recording...

- 1** Press C. RESET.
 - The counter will be reset to "0H 00M 00s", and will show the exact elapsed time as the tape runs.
- 2** After starting recording, press OSD at any time to check the elapsed time on the TV screen.
- 3** Press OSD again to clear it from the screen.

Recording (cont'd)

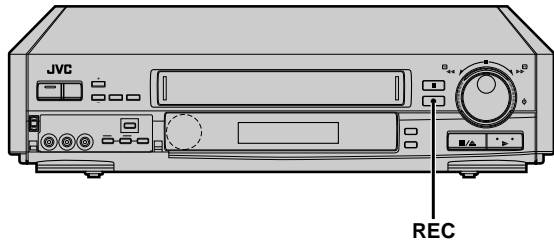

REC

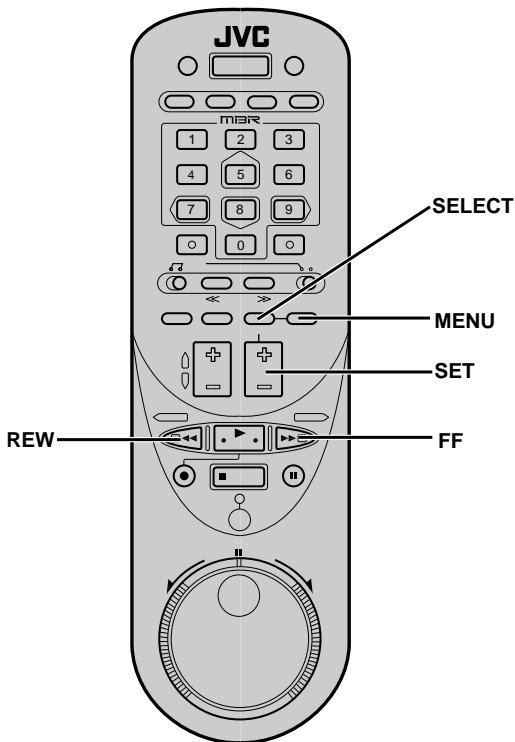

Instant Timer Recording

To set the VCR to shut-off automatically after recording.

During Recording...

- 1 Press the VCR's REC button. The "ITR" indication blinks and "0:30" appears indicating the recording will continue for 30 minutes and then power will switch off.

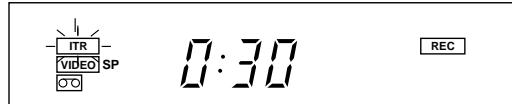

- 2 Press REC again to extend the record time by 30-minute increments (up to 9 hours).
 - This function is available only using the REC button on the VCR.
 - After the off-time is set, the display returns to the previously displayed mode (counter, channel or clock).
 - You can check the time remaining before the VCR shuts off by pressing REC once; the remaining time is displayed for 5 seconds. (Pressing REC more than once will extend the record time.)

Hi-Fi Audio Recording Level Control

Your VCR allows manual adjustment of the Hi-Fi audio recording level. Although the preset audio recording level is satisfactory for normal recording, if the sound you are going to record is too loud or too low, adjust the audio recording level while referring to the VCR's audio level meters.

- 1 Press MENU, SET, and SELECT as many times as necessary to access the HI-FI REC LEVEL CONTROL screen. (See p.7)
- 2 Press SET to choose "MANUAL".
- 3 Press FF or REW to adjust the audio recording level.

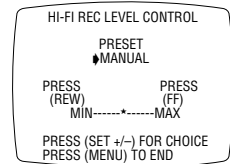

- To move the on-screen's audio levels by one division of the scale, press FF or REW briefly for 5 times in succession. To move the audio levels faster, keep FF or REW pressed.
 - Adjust the recording level so that the audio level meters reach from 0dB to 4dB at the maximum sound volume.
- 4 Press MENU as many times as necessary to exit.

NOTE:

- Noise will increase if the recording level is too low, while distortion will increase if the level is too high.

Accidental erasure prevention

- To prevent accidental recording on a recorded cassette, remove its safety tab. To record on it later, cover the hole with adhesive tape.

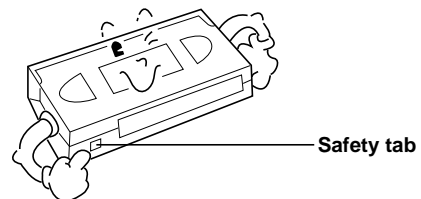

Safety tab

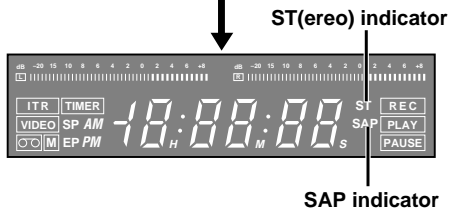
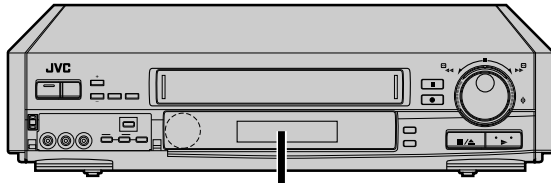
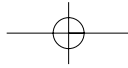

Stereo and SAP (Second Audio Program)

Your VCR is equipped with an MTS decoder for reception of Multichannel TV Sound broadcasts.

- When a stereo program is being received, the ST indicator lights.
- When an SAP program (such as a bilingual broadcast) is being received, the SAP indicator lights.
- When a stereo program is accompanied by SAP audio, both indicators light.

To record stereo programs

Stereo programs are automatically recorded in stereo on the Hi-Fi audio track. No special operation is required. Simply follow the basic recording procedure.

- To listen to the stereo soundtrack while recording, set the on-screen AUDIO MONITOR to "HI-FI". (p. 18).

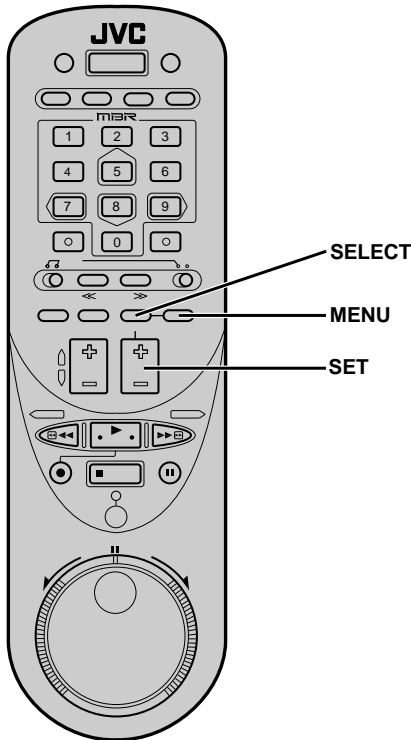

To record SAP programs

- 1 Press MENU, SET, and SELECT as many times as necessary to access the 2ND AUDIO screen. (p. 7).
- 2 Press SET to choose "ON".
- 3 Press MENU as many times as necessary to exit.

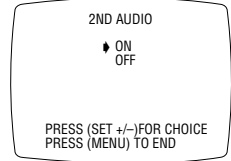

Then follow the basic recording procedure.

- If an SAP program is received, the SAP audio will be recorded on both the Hi-Fi and the normal audio tracks. The main audio program will not be recorded.
- If a regular program (non-SAP) is received, the main audio will be recorded on both the Hi-Fi and the normal audio tracks.

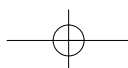



Timer-Recording with VCR Plus+

Your video recorder is equipped with the VCR Plus+ programming system. This programming system greatly simplifies timer programming because you won't have to enter all the data that is usually necessary (such as date, start and stop time, and channel). Simply key-in the PlusCode number for the TV program you wish to record and the VCR's timer will be programmed. The PlusCode

VCR Plus+ programming is not possible unless you have already....

- set the VCR's clock
- set the VCR's tuner
- made necessary changes in the Guide Channel Set screen.

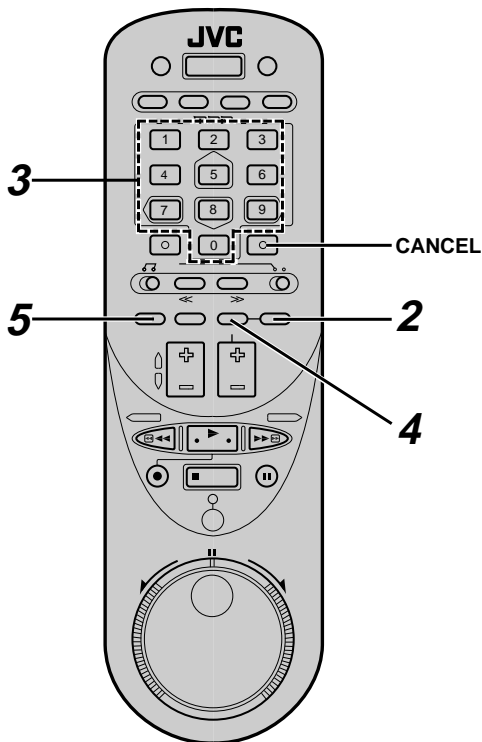
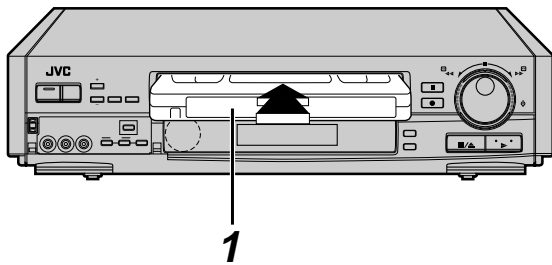

LOAD A CASSETTE

- 1 Insert a cassette with the safety tab present.
 - The VCR power will come on automatically.
 - If watching on channel 3 or 4 be sure that the VIDEO indicator is lit. If the indicator is not lit press TV/VIDEO so that it lights.

INPUT THE TV PROGRAM'S CODE NUMBER

- 2 Press MENU.
 - The "VCR PLUS+" input screen will be displayed.

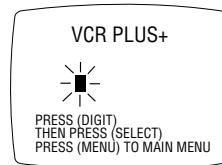

- 3 Press the Digit keys to enter the PlusCode number for the TV program you wish to record.
 - To make corrections, press CANCEL and re-input with Digit keys.

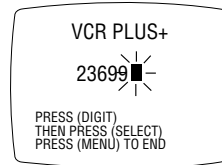

CHECK FOR CORRECTNESS

- 4 Press SELECT.
 - The settings for the PlusCode number you just entered will be displayed.
 - If the settings are incorrect and do not match the program you wish to record, press CANCEL and, after pressing MENU three times, re-input the PlusCode number.

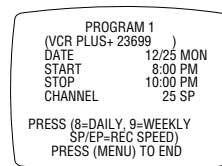

SELECT THE TAPE SPEED

- 5 Press SP/EP.

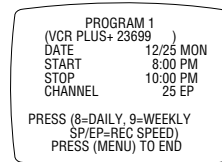

(Continued on next page.)

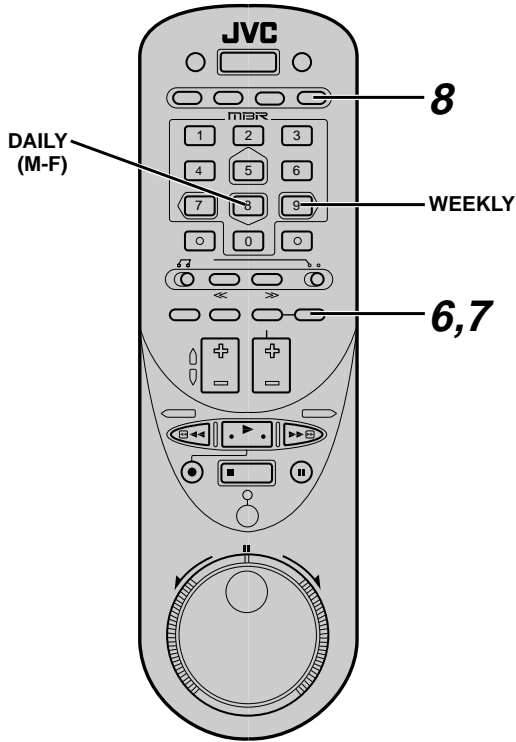
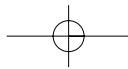

RETURN TO THE TV SCREEN

- 6** Press MENU.
 - Select the desired Auto Timer setting. See page 30 for details.
- 7** Press MENU again.

SET TO TIMER MODE

- 8** Press TIMER.
 - The VCR will enter the timer mode and power will go off.

For AUTO TIMER and other timer programming features, see p. 30.
 For other error indications, see p. 37.

To Timer-Record Daily Serials

This function lets you set the recorder to timer-record at the same time every day, Monday through Friday.
 ■ After pressing SELECT in step 4, press DAILY (Digit key 8). "DAILY" will appear.

To Timer-Record Weekly Serials

This function lets you set the recorder to timer-record at the same time on the same day every week.
 ■ After pressing SELECT in step 4, press WEEKLY (Digit key 9). "WEEKLY" will appear.

TO MAKE CHANGES IN THE SETTINGS

You can delay a program's stop time or make other such "revisions" in the settings.

- 1** After step 5, press SELECT.
- 2** Press SELECT to move to the setting you wish to change, so that it blinks.
- 3** Press SET to make the change.
- 4** Return to step 6.

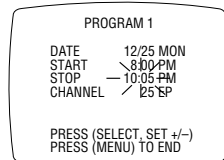

"ERROR" WARNING

If the PlusCode number you input is incorrect, "ERROR" may appear on the screen to advise you of the error. This happens when the code is for a program which has already passed. "ERROR" is displayed for about 4 seconds and returns to the input screen (step 2).

VCR PLUS+
 23699
 ERROR
 PRESS (DIGIT) THEN PRESS (SELECT) PRESS (MENU) TO END

TO DISENGAGE THE TIMER

For safety, when AUTO TIMER is "OFF", your VCR disables all other functions while in the timer mode.

- To use your VCR, first disengage the timer mode by pressing TIMER again. Now all functions will be operable.
- To re-engage the timer, press TIMER.

NOTES:

- If there is a power failure the VCR will remember your timer-record selections for 10 minutes.
- If a program that is being timer-recorded sends a timer-extension signal, the VCR automatically extends recording time to accommodate the change. (INDEX PLUS+ FUNCTIONS SETTING must be set to "ON". Refer to page 8 of the INDEX Plus+ manual.)

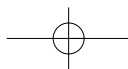



Timer-Recording without VCR Plus+

POR INSTRUCCIONES EN ESPAÑOL VEA p. 40 – 41.

With the On-Screen Timer Programming function introduced here you can directly program the VCR's timer to record up to 8 TV shows, up to a year ahead. It's especially convenient when you want to timer-record programs while you're away from home for long periods of time (over a week), or for TV programs listed without a PlusCode. **TIMER PROGRAMMING IS NOT POSSIBLE UNLESS THE CLOCK HAS BEEN SET.**

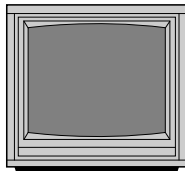

**POWER ON;
SELECT CHANNEL
3 OR 4 (OR AV MODE)**

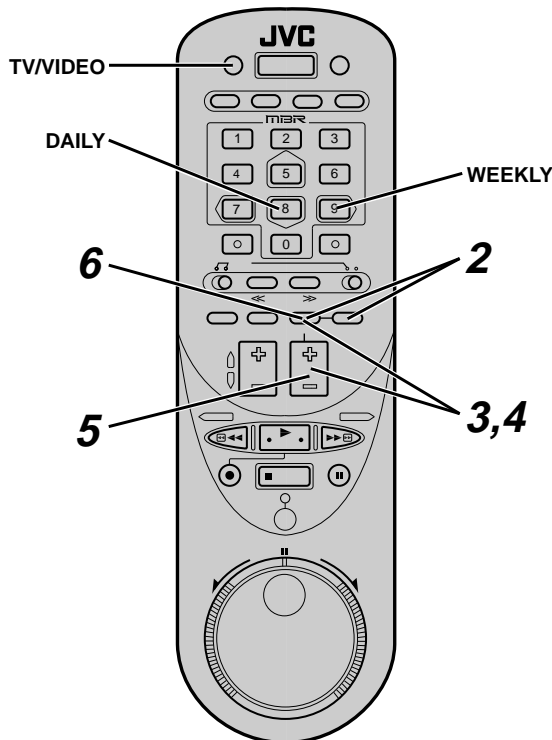
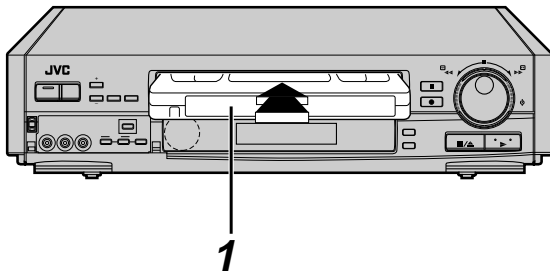

You can also use the MENU, SET and SELECT buttons on the VCR.

LOAD A CASSETTE

- 1** Insert a cassette with the safety tab present.
 - The VCR power will come on automatically. If watching on channel 3 or 4 be sure that the VIDEO indicator is lit. If the indicator is not lit, press TV/VIDEO so that it lights.
 - If the clock has not been set, set the clock before starting step 2. [p. 9](#)

ACCESS THE ON-SCREEN MENU

- 2** Press MENU twice and then press SELECT.
 - The Program Set screen will appear.

SELECT A PROGRAM NUMBER

- 3** Press SET to move to a vacant program number, and then press SELECT.
 - Initially all programs are vacant, and the cursor is at program 1. So simply press SELECT.

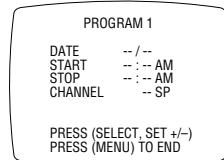

INPUT THE DATE

- 4** Press SET to set the month, and then press SELECT.
- 5** Press SET to set the day.
 - The day of the week will automatically appear.
 - To record the program daily (Mon-Fri) press DAILY (Digit key 8). To record the program weekly press WEEKLY (Digit key 9). "DAILY" or "WEEKLY" will appear on the screen.
- 6** Press SELECT.

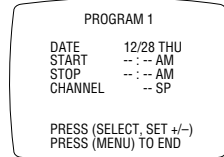

(Continued on next page.)

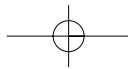

"ERROR" WARNING

If the start time you input has already passed (i.e. is prior to the present date and time), the VCR will flash "ERROR" on the Program Set screen.

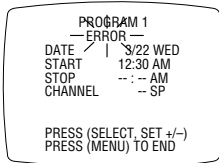

Check if you've input the correct time and date. Remember: late night shows beginning at midnight or later must have the next day's date.

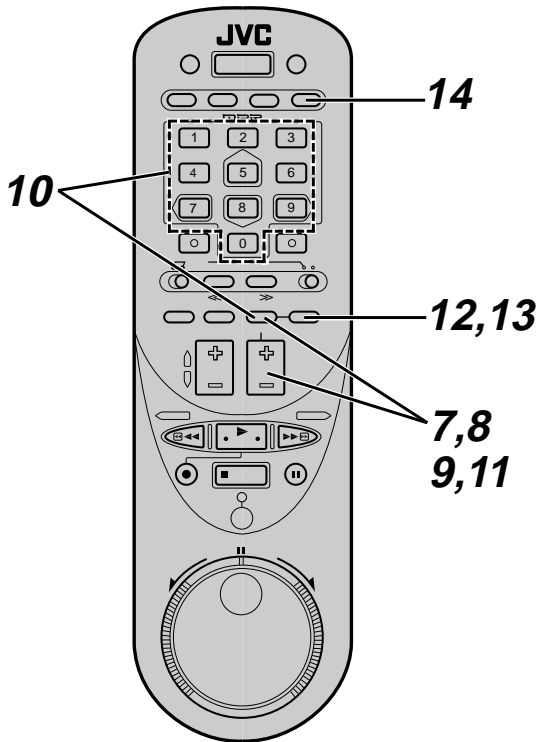

NOTES:

- If there is a power failure, the VCR will remember your timer-record selections for 10 minutes.
- When timer-recording cable channels received through a Converter Box, be sure to keep the Converter Box set to ON.
- If a date before the present date is selected the timer will be set for that date next year. The day displayed will also change to reflect the correct day for that date next year.
- If a program that is being timer-recorded sends a timer-extension signal, the VCR automatically extends recording time to accommodate the change. (INDEX PLUS+ FUNCTIONS SETTING must be set to "ON". Refer to page 8 of the INDEX Plus+ manual.)

INPUT THE START TIME

- 7** Press SET to set the hour (making sure that AM or PM is correct), and then press SELECT.
- 8** Press SET to set the minutes, and then press SELECT.

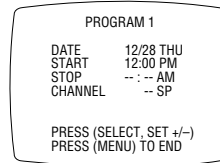

INPUT THE STOP TIME

- 9** Set the stop time in the same way as you set the start time in steps 7 – 8.

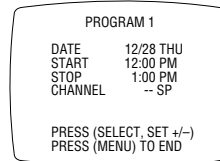

INPUT THE CHANNEL NUMBER

- 10** Press the Digit keys to enter the channel number, and then press SELECT.

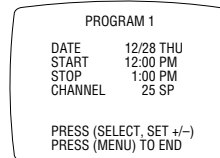

SET THE TAPE SPEED

- 11** Press SET to choose SP or EP, and then press SELECT.
 - To input another program, repeat steps 3 – 11. (You can set up to a maximum of 8 programs.)

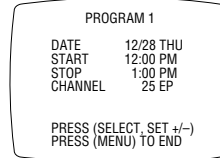

RETURN TO THE TV SCREEN

- 12** Press MENU.
 - Select the desired Auto Timer setting. See page 30 for details.
- 13** Press MENU again.

SET TO TIMER MODE

- 14** Press TIMER.
 - The VCR will enter the timer mode and power will go off.

For AUTO TIMER and other timer programming features, see p. 30. For other error indications, see p. 37.

TO DISENGAGE THE TIMER

- For safety, when AUTO TIMER is "OFF", your VCR disables all other functions while in the timer mode.
- To use your VCR, first disengage the timer mode by pressing TIMER again. Now all functions will be operable.
 - To re-engage the timer, press TIMER.

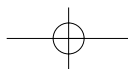



Timer-Recording (cont'd)

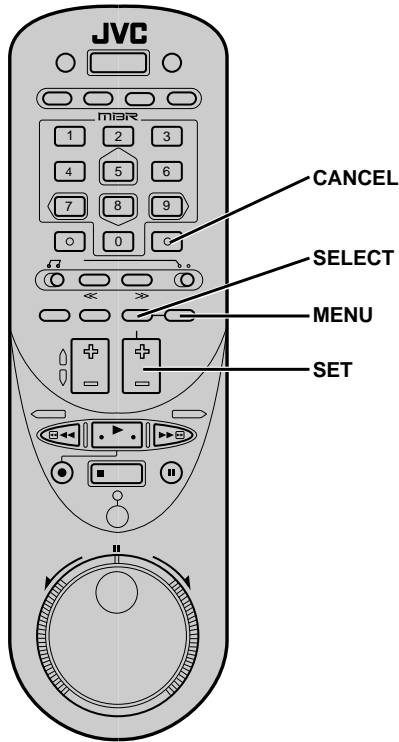
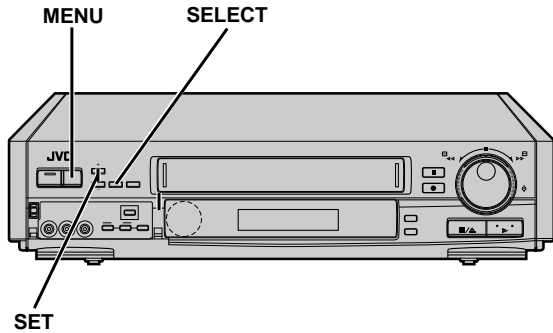

Auto Timer

What this feature does: Usually, the timer mode is not engaged unless the TIMER button is pressed. But with AUTO TIMER set to ON, the timer mode is automatically engaged when the VCR's power is turned off, and is disengaged whenever VCR power is turned on again.

- 1 After step 6 (p. 27) or step 12 (p. 29), press SET to choose "ON", and press MENU.

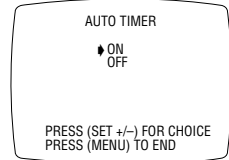

Or...

- 1 Press MENU, SET, and SELECT as many times as necessary to access the AUTO TIMER screen. (p. 7)
- 2 Press SET to choose "ON".
- 3 Press MENU as many times as necessary to exit.

To check and cancel programs

Make sure the timer mode is disengaged first. Then...

- 1 Press MENU and then press SELECT (to access the Program Set screen).
- 2 Press SET to check through the programs in succession.

To cancel the program...

- 3 Press CANCEL.
 - Repeat steps 2 and 3 as necessary.
- 4 Press MENU as many times as necessary to exit.



Special Features

The provided remote control is capable of controlling 10 different TV brands including JVC and 13 different Cable Box brands. Follow the instructions below to set the appropriate code for your TV or Cable Box.

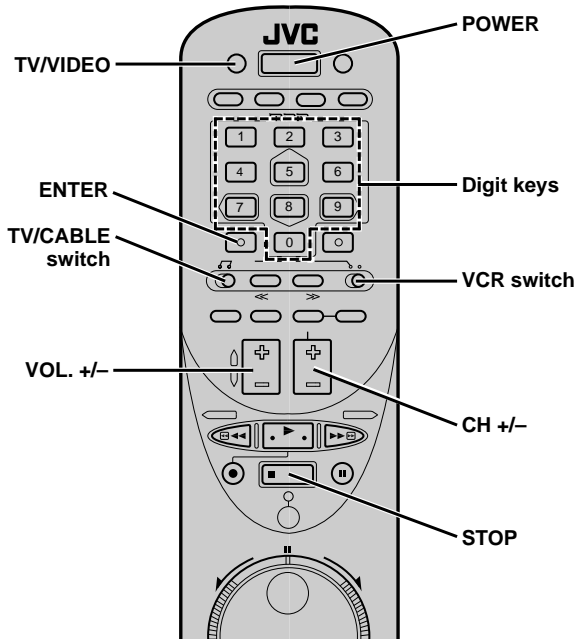

TV Multi-Brand Remote Control

If your TV is a JVC, you don't have to set the TV code.

PREPARATION

- 1 Turn off the TV by using the TV's remote control.
- 2 Set the VCR switch to the left.
- 3 Set the TV/CABLE switch to "TV".
- 4 While holding down the POWER button, enter your TV's brand code with the Digit keys then press STOP.
 - Brand setting is completed. Once you set the brand, you do not have to reset it until the remote's batteries are replaced.
 - If you set the wrong code, re-enter the right code.
- 5 Press POWER to turn the TV power on and check to see if the remote control works with the TV.

OPERATION

- 1 Set the VCR switch to the left.
- 2 Set the remote control's TV/CABLE switch to "TV".
- 3 Operate the TV.
 - POWER, TV/VIDEO, CH +/-, VOL. +/- buttons and Digit keys are available.
- 4 To operate VCR, set the VCR switch to "VCR".

Cable Box Multi-Brand Remote Control

Some Cable Box brands have more than one code. When your Cable Box does not function with a specified code, try other codes.

PREPARATION

- 1 Turn off the Cable Box by using the Cable Box's remote control.
- 2 Set the VCR switch to the left.
- 3 Set the TV/CABLE switch to "CABLE".
- 4 While holding down the POWER button, enter your Cable Box's brand code with the Digit keys then press STOP.
 - Brand setting is completed. Once you set the brand, you do not have to reset it until the remote's batteries are replaced.
 - If you set the wrong code, re-enter the right code.
- 5 Press POWER to turn the Cable Box's power on and check to see if the remote control works with the Cable Box.

OPERATION

- 1 Set the VCR switch to the left.
- 2 Set the remote control's TV/CABLE switch to "CABLE".
- 3 Operate the Cable Box.
 - POWER and CH +/- buttons are available.
- 4 To operate VCR, set the VCR switch to "VCR".

NOTES:

- It is necessary to set the cable box brand in your remote control (this page) and the Cable Box Controller (p. 14) individually. With the remote control, you can change channels using the CH +/- button and turn on/off your cable box. With the Cable Box Controller, your cable box's channels can be automatically changed during timer-recording.
- Cable box brands available for the remote control (listed on the left) differ from those that are available for the Cable Box Controller (p. 14).
- It is possible that the remote control will not operate your cable box even if the cable box's channels automatically change during timer-recording using the Cable Box Controller.

TV Brand Name And Code

TV BRAND NAME	BRAND CODE
JVC	01
MAGNAVOX	02
MITSUBISHI	03
PANASONIC	04
RCA	05
SHARP	06
SONY	07
TOSHIBA	08
ZENITH	09
HITACHI	10

Cable Box Brand Name And Code

CABLE BOX BRAND NAME	BRAND CODE
GI	01,02,03,04,05,06,07,08
JERROLD	01,02,03,04,05,06,07,08
SCIENTIFIC ATLANTA	09,10
ZENITH	11,12
PIONEER	13,14
HAMLIN	15,16,17,18
REGAL	15,16,17,18
OAK	19,20,21
SIGMA	19,20,21
TOCOM	22,23
RCA	24,25,26
PANASONIC	24,25,26
SPRUCER	24,25,26

▶ Editing

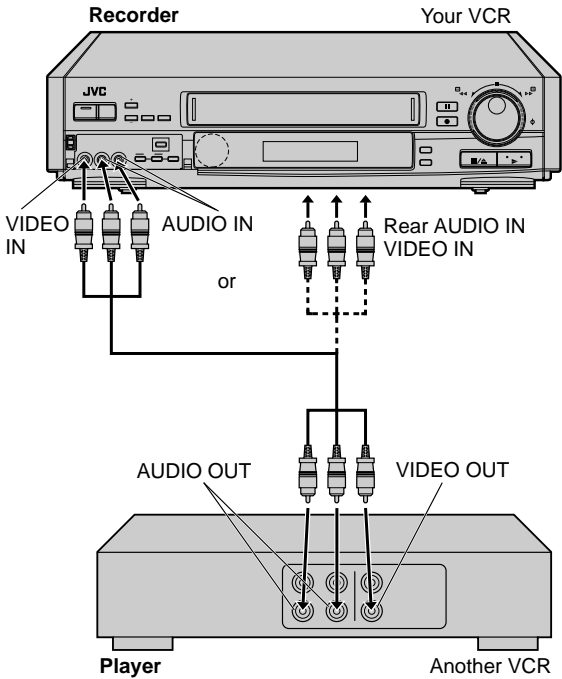

To edit to or from another VCR

Your VCR can be used as either the recording deck or the source player when editing tapes.

PREPARATION

- 1 Connect the player's VIDEO OUT and AUDIO OUT connectors to the recorder's VIDEO IN and AUDIO IN connectors.
 - When using your VCR as a recorder and connecting it to a monaural deck, connect that deck's AUDIO OUT connector to your VCR's AUDIO IN L connector.

OPERATION

- 2 Press MENU, SET, and SELECT as many times as necessary to access the AUX INPUT screen. (p. 7)
- 3 Press SET to choose "FRONT" or "REAR".
 - Select FRONT to connect to the front panel connectors.
 - Select REAR to connect to the rear panel connectors.
- 4 Press MENU as many times as necessary to exit.
- 5 Set the recorder's input mode to AUX.
 - With this VCR model, press the digit key "0". "AU" will appear instead of a channel number.

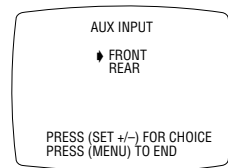

FOR ASSEMBLE EDITING

Assemble editing adds one recorded scene to another in succession. To use your VCR as the recording deck...

- 6 Load the source tape in the player, and the recording tape in your VCR.
- 7 Select the recording speed (SP or EP).
- 8 Put your VCR in the Record-Pause mode.
- 9 Play back the source tape to search for a scene to be edited.
- 10 Press the recorder's PLAY button where you want to start editing.
- 11 Press the recorder's PAUSE button to stop editing.
- 12 Repeat steps 9 through 11 to continue editing. (Assemble Editing is also possible using your VCR as the playback deck.)

FOR INSERT EDITING

Insert editing replaces part of the recorded scene with new material. Both the picture and Hi-Fi audio soundtrack are replaced with new ones, while the normal audio soundtrack remains unchanged. Use your VCR as the recording deck.

- 6 Load the source tape in the player, and the recording tape in your VCR.
- 7 Play back the recording tape and engage the Still mode at the edit-in point (the beginning of the segment to be replaced).
- 8 Press INSERT.
 - Your VCR enters the Insert-Pause mode. (REC, PLAY and PAUSE light up on the FDP.)
 - The TV screen changes from the still picture to the input signal you are going to record.
- 9 Play back the segment of the source tape to be inserted.
- 10 Press PLAY on the recorder.
 - Insert editing will start. (PLAY and REC are displayed on the FDP.)
- 11 Press PAUSE on the recorder to stop insert editing.
 - Do not press STOP to stop insert editing, otherwise the picture will be distorted at the switching point between the newly inserted and previously recorded pictures.

FOR AV INSERT EDITING

If you want to replace the picture, Hi-Fi audio soundtrack and normal audio soundtrack all at the same time...

In step 8 above, after you press INSERT, press A. DUB. also. (REC and PLAY blink and PAUSE lights up on the FDP.)

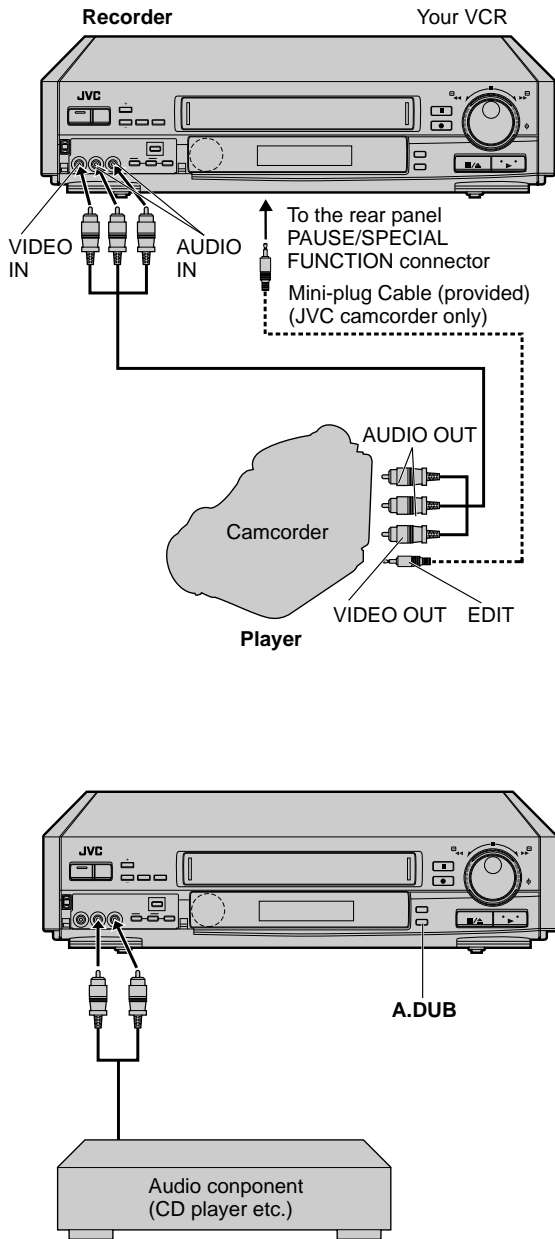

NOTES:

- After audio dubbing, the normal audio track remains selected. To hear the Hi-Fi tracks, select "Hi-Fi" (p.18).
- Audio dubbing is possible using the rear connectors.
- The AUX INPUT must be selected as the audio source.
- Audio dubbing will stop automatically at the counter reading of "0:00:00", and the recorder will enter the Play mode. Check the counter before starting audio dubbing.

To edit from a camcorder

Tape-to-tape editing is also possible using a camcorder (equipped with playback facility) as the player and your VCR as the recorder.

PREPARATION

- 1 Connect the camcorder's VIDEO OUT and AUDIO OUT connectors to the VCR's front panel VIDEO IN and AUDIO IN connectors. If using a master edit control equipped JVC camcorder connect the PAUSE/SPECIAL FUNCTION connector on the rear of the VCR to the REMOTE/EDIT OUT connector on the camcorder.
 - Use the L connector for monaural connection.
 - When a Master Edit Control-equipped JVC camcorder is used, the camcorder is capable of controlling your VCR.
 - ① Press MENU, SET, and SELECT as many times as necessary to access the SPECIAL FUNCTION screen. (p. 7)
 - ② Press SET to choose "R.A.EDIT/PAUSE".
 - ③ Press MENU as many times as necessary to exit.
 - Refer to camcorder's instruction manual for set-up procedure.

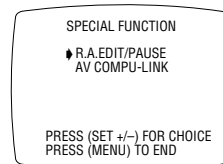

OPERATION

- 2 Press MENU, SET and SELECT as many times as necessary to access the "AUX INPUT" screen. (p. 7)
- 3 Press SET to choose "FRONT".
- 4 Press MENU as many times as necessary to exit.
- 5 Set the VCR's input mode to AUX by pressing digit key "0". "AU" will appear instead of a channel number.
- 6 Put the camcorder in the Play mode.
- 7 Put the VCR in the Record mode.
 - Refer to the camcorder/recorder's instruction manual for operation instructions.

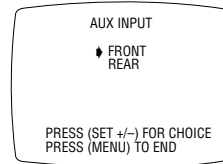

Audio Dubbing

Audio Dubbing replaces the normal audio sound of a previously recorded tape with a new soundtrack.

PREPARATION

- 1 Connect an audio component to the recorder's front panel AUDIO L, R connectors. (For monaural equipment, use the L connector.)

OPERATION

- 2 Press MENU, SET and SELECT as many times as necessary to access the "AUX INPUT" screen. (p. 7)
- 3 Press SET to choose "FRONT".
- 4 Press MENU as many times as necessary to exit.
- 5 Set the VCR's input mode to AUX by pressing digit key "0". "AU" will appear instead of channel number.
- 6 Start playback and engage the Still mode at the point from which you wish to start audio dubbing.
- 7 Press A. DUB.
 - Your VCR enters the Audio Dubbing-Pause mode. (REC blinks, PLAY and PAUSE light up on the FDP.)
- 8 Start playback of the audio source, and then press PLAY.
 - Audio dubbing will start. (REC blinks and PLAY is displayed on the FDP.)
- 9 Pressing PAUSE temporarily stops audio dubbing.
- 10 Press STOP to stop audio dubbing.

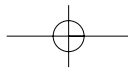

▶ ● Editing (cont'd)

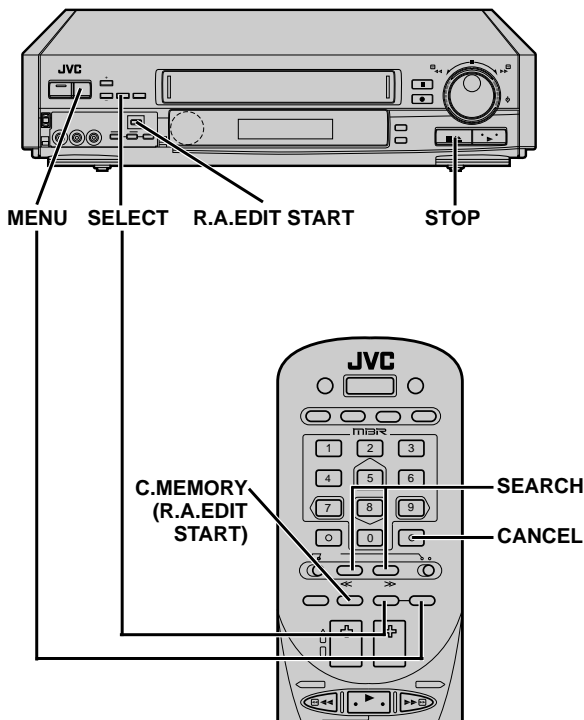
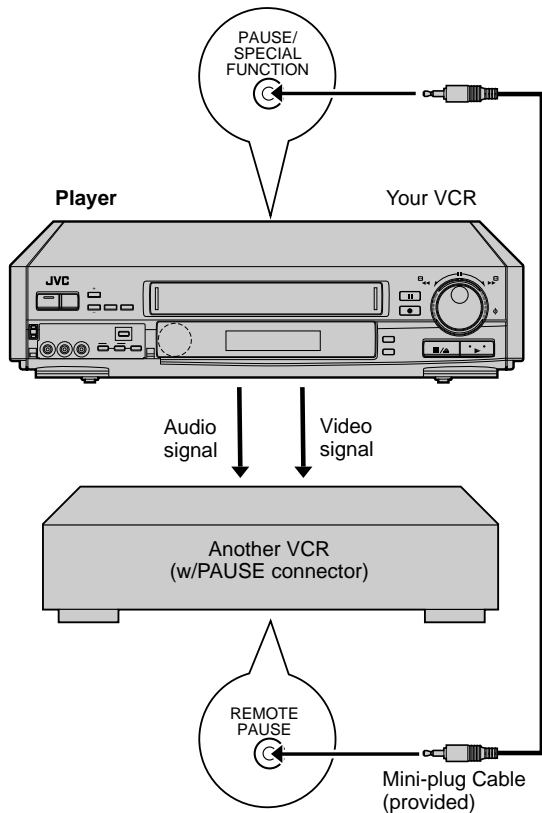

Random Assemble Editing

This function makes it easier to create edited videos when your VCR is used as the source player in combination with another video deck which is equipped with a PAUSE (i.e. REMOTE PAUSE) terminal. You can pre-program up to 8 scenes or "cuts" for automatic editing in the sequence you have specified.

PREPARATION

- 1 Connect your VCR's VIDEO OUT and AUDIO OUT connectors to the recording deck's VIDEO IN and AUDIO IN connectors.
- 2 Connect your VCR's PAUSE/SPECIAL FUNCTION connector to the recording deck's PAUSE connector with the supplied mini-plug cable.
 - If the recording deck does not have a PAUSE connector, connect to the R.A. EDIT connector.
- 3 Turn both units on.
- 4 Engage the recorder's AUX(iliary) mode.
- 5 Press MENU, SET, and SELECT on the player as many times as necessary to access the SPECIAL FUNCTION screen.

SPECIAL FUNCTION
 ◆ R.A. EDIT/PAUSE
 AV COMPU-LINK
 PRESS (SET +/-) FOR CHOICE
 PRESS (MENU) TO END
- 6 Press SET to choose "R.A. EDIT/PAUSE".
- 7 Press MENU as many times as necessary to exit.

OPERATION

- 8 Insert a recorded cassette into your VCR.
- 9 Play back the tape in your VCR.
- 10 Press MENU, SET and SELECT as many times as necessary to access the R.A. EDIT screen.
 - The screen is superimposed on the video playback.
- 11 Use the SEARCH buttons to search for the point where you want an edited scene to start, and press SELECT.
 - The cut-in point is registered in memory.
- 12 Use the SEARCH buttons to search for the point where you want the scene to end, and press SELECT.
 - The cut-out point is registered in memory.
 - The "TTL" reading displays the total running time of the edited scenes.
- 13 Specify additional scenes by repeating steps 11 - 12.

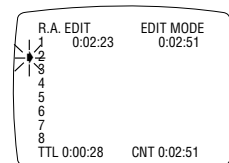
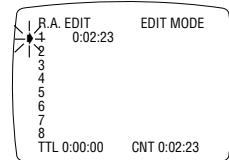
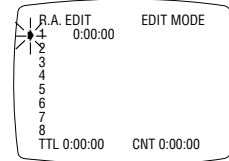

(Continued on next page.)

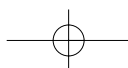

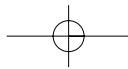

14 Insert a cassette (with safety tab intact) into the recording deck, and put the recording deck in the Record-Pause mode.

15 Press R.A.EDIT START.

- The function begins automatic editing; all the specified scenes are copied to the recording deck in sequential order.
- The on-screen display remains superimposed while your VCR searches for each scene (the blinking cursor points to the scene number presently being searched), and is not displayed while the scenes are being edited.
- While a scene is being searched, the recording deck automatically enters the Record-Pause mode. "SEARCHING" appears on the screen.
- When Random Assemble Editing is finished, your VCR enters the Still mode, the recording deck enters the Record-Pause mode, and the cursor blinks at the next available scene number.

16 Press MENU as many times as necessary to exit.

17 Press STOP on both decks to end Random Assemble Editing.

R.A. EDIT SEARCHING

1	0:02:23	0:02:51
2	0:10:20	0:21:40
3	0:03:16	0:05:39
4	0:25:33	0:25:47
5	0:56:21	1:00:36
6		
7		
8		

TTL 0:18:40 CNT 0:02:30

R.A. EDIT EDIT MODE

1	0:02:23	0:02:51
2	0:10:20	0:21:40
3	0:03:16	0:05:39
4	0:25:33	0:25:47
5	0:56:21	1:00:36
6		
7		
8		

TTL 0:18:40 CNT 1:00:36

TO MAKE CORRECTIONS

During step 11 or 12, you can correct a cut-in or cut-out point using the remote control. Each time the CANCEL button is pressed, the immediately preceding point is cleared and can be reset.

- Example: The cut-out point for "2" can be changed by pressing CANCEL once (to clear it) and re-setting it. By pressing CANCEL more times, you can back up to previous points for re-setting, **but all points in between will be cleared** in the process. (e.g. To reach the cut-out point for "1", the cut-in and -out points for "2" will be cleared.)

R.A. EDIT EDIT MODE

1	0:02:23	0:02:51
2	0:10:20	0:21:40
3		
4		
5		
6		
7		
8		

TTL 0:11:48 CNT 0:21:40

MEMORY CAPACITY

Random Assemble Editing utilizes the same memory space as the VCR's timer; so the number of sequences available to this function may not be 8, depending on how many programs are already stored in memory.

- Example: Only sequences 1 – 5 are available because three programs are stored in the timer memory.
- Example: The "PROGRAM FULL" screen appears when the timer memory is full (all 8 programs are used). To cancel a program, see p. 30.

R.A. EDIT EDIT MODE

1		
2		
3		
4		
5		
6		
7		
8		

TTL 0:00:00 CNT 0:01:30

R.A. EDIT EDIT MODE

PROGRAM FULL

TTL 0:00:00 CNT 0:01:30

"ERROR" WARNING

If you choose "AV COMPU-LINK" by mistake in step 6 and then reach the R.A. EDIT screen in step 10, the "ERROR" display will appear as shown on the right.

Be sure to choose "R.A. EDIT/PAUSE" in step 6 to perform Random Assemble Editing.

-ERROR-

CHOOSE SPECIAL FUNCTION
ON MAIN MENU AND SELECT
R.A. EDIT/PAUSE

BEFORE YOU BEGIN
R.A. EDIT

PRESS (MENU) TO MAIN MENU

OPTIONAL RM-V403U MULTI-BRAND R.A.EDIT CONTROLLER

By connecting this controller to your VCR's R.A.EDIT Connector, Random Assemble Editing will become possible in conjunction with a second non-JVC VCR. The controller is compatible with various major VCR brands — convenient especially if you already own a VCR other than JVC. For compatible systems and availability, please consult your JVC dealer.

USING INDEX SEARCH WITH RANDOM ASSEMBLE EDITING

In step 11, Index Search can also be used to locate your edit points. When used, "INDEX" and the index number will appear on the R.A.Edit screen. For Index Search see p. 20.

- Using Index Search during R.A.Edit will result in a reduction in accuracy.
- This function requires that index marks are previously recorded on your tape at the desired edit points.

NOTE:
 You can also monitor the sound when searching for scenes you want to edit in steps 11 – 12.
 Since you can hear the soundtrack during selection, you can avoid abrupt or unnatural sounding scene-to-scene connections.

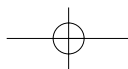

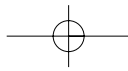

? If You Have Any Questions

Before requesting service...

Power or Tape Transport Problems?

Symptoms	Check points
No power is applied to the VCR.	<ul style="list-style-type: none"> ■ Is the power cord disconnected? — Connect it.
Remote control does not function.	<ul style="list-style-type: none"> ■ Are the batteries discharged? — Replace with new ones. ■ Is the remote control's A/B code setting correct? (☞ p. 22) ■ Are the VCR/TV/CABLE control select switches set to their appropriate position? (☞ p. 5) — Check once again.
Clock is functioning properly, but the VCR cannot be powered.	<ul style="list-style-type: none"> ■ Is "TIMER" displayed on the display panel? — Press the TIMER button to extinguish the display.
Cassette will not load. Gets stuck and is ejected a few seconds later.	<ul style="list-style-type: none"> ■ Are you inserting the cassette correctly? Incorrect insertion causes the built-in safety mechanism to automatically eject the cassette. — Wait a few seconds and re-insert correctly. — Be sure to push the middle of the cassette's label side and be sure the window side is up.
Tape stops during rewind or fast-forward.	<ul style="list-style-type: none"> ■ Is the C. MEMORY button pressed? — Press again to make "M" disappear from the counter display.
Tape will not rewind or fast-forward.	<ul style="list-style-type: none"> ■ Is the tape already fully rewound or fast-forwarded? — Check the cassette.

Playback Problems?

Symptoms	Check points
Playback picture does not appear while the tape is running.	<ul style="list-style-type: none"> ■ If you are using RF OUT connection, is the TV receiver's channel selector set to the correct video channel? — Set it to the RF converter channel (3 or 4). (☞ p. 8) ■ If you are using AV connection, is the TV receiver set to the AV mode? — Set it to the AV mode.
Noise appears during visual search.	<ul style="list-style-type: none"> ■ This is normal.
Noise appears during normal playback.	<ul style="list-style-type: none"> ■ Is the automatic tracking mode engaged? — Try manual tracking. (☞ p. 17)
Noise appears during slow playback.	<ul style="list-style-type: none"> ■ Try manual tracking. (☞ p. 17) ■ This is normal in the LP mode.
Playback picture is blurred or interrupted while TV broadcasts are clear.	<ul style="list-style-type: none"> ■ Video heads may be dirty. — Head cleaning is necessary. Consult your JVC dealer (☞ p. 39).
Breaks are noticeable in Hi-Fi audio sound.	<ul style="list-style-type: none"> ■ Is the automatic tracking mode engaged? — Try manual tracking. (☞ p. 17).
Hi-Fi soundtrack cannot be heard.	<ul style="list-style-type: none"> ■ Is "AUDIO MONITOR" on the FUNCTION menu set to "NORM"? — Set it to "HI-FI" (☞ p. 18). ■ Is Hi-Fi audio present on the tape?

Recording Problems?

Symptoms	Check points
Recording cannot be started.	<ul style="list-style-type: none"> ■ Is a cassette loaded? ■ Is the safety tab on the cassette removed? — Cover with adhesive tape. (☞ p. 24)
TV broadcasts cannot be recorded.	<ul style="list-style-type: none"> ■ Has "AUX" been selected by mistake? — Set to the desired channel.
Tape-to-tape editing is not possible.	<ul style="list-style-type: none"> ■ Is the camcorder or VCR correctly connected? ■ Are all necessary power switches turned ON? ■ Has "AUX" been selected? — Set to "AUX". ■ Have the correct inputs been selected? — Make sure the correct inputs (FRONT or REAR) have been selected on the AUX INPUT screen. (☞ p. 32, 33)
Camera recording is not possible.	<ul style="list-style-type: none"> ■ Is the camcorder correctly connected? ■ Has "AUX" been selected? — Set to "AUX".

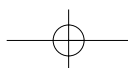

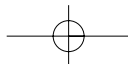

Timer-Recording Problems?

Symptoms	Check points
Timer recording is not possible.	<ul style="list-style-type: none"> ■ Have you set the clock correctly and programmed the timer correctly? <ul style="list-style-type: none"> — Check once again. ■ Have you set-up the VCR? Make sure you have... <ul style="list-style-type: none"> — Set the VCR's tuner. — Made necessary changes in the Guide Channel Set screen. ■ Is the TIMER indicator displayed on the display panel? <ul style="list-style-type: none"> — If not, press the TIMER button to display the TIMER indicator.
Cable channels are not automatically switched during timer-recording.	<ul style="list-style-type: none"> ■ Make sure that... <ul style="list-style-type: none"> — The Cable Box Controller is connected to your VCR's CABLE BOX Connector (☞ p. 12). — The correct Cable Box output channel selected in the CABLE BOX OUTPUT menu (☞ p. 13). — The Cable Box's power is left ON during timer-recording. ■ Although the provided Cable Box Controller is compatible with many different cable box brands, it is possible that it will not work with your cable box.
Timer recording takes place, but the channel is always wrong.	<ul style="list-style-type: none"> ■ Is CABLE BOX OUTPUT menu set to "ON" even though you don't use an external Cable Box? <ul style="list-style-type: none"> — If you don't use a Cable Box, set CABLE BOX OUTPUT menu to "OFF". (☞ p. 13).
We moved, and now VCR Plus+ doesn't work properly.	<ul style="list-style-type: none"> ■ TV stations differ by locale. It may be necessary to re-set the VCR. (☞ p. 15).
"PROGRAM FULL" is displayed on the VCR Plus+ input screen.	<ul style="list-style-type: none"> ■ The VCR's timer memory is full; all 8 programs are used. <ul style="list-style-type: none"> — Cancel any unnecessary programs in the timer memory (☞ p. 30).
Timer programming screen does not function properly.	<ul style="list-style-type: none"> ■ Is the ITR indicator displayed on the display panel? <ul style="list-style-type: none"> — Timer programming is not possible while an ITR is in progress.
"TIMER" and "☐☐" on the display panel continue blinking.	<ul style="list-style-type: none"> ■ There is no cassette in the VCR. <ul style="list-style-type: none"> — Insert a cassette with the safety tab intact.
The cassette is automatically ejected. "TIMER" and "☐☐" continue blinking.	<ul style="list-style-type: none"> ■ The inserted cassette has its safety tab removed. <ul style="list-style-type: none"> — Insert a cassette with its safety tab intact. Or cover the safety tab hole of the cassette with adhesive tape and re-insert it (☞ p. 24).
"TIMER" blinks for 10 seconds and the timer mode is cancelled.	<ul style="list-style-type: none"> ■ There are no preset programs in memory, or they have all been incorrectly preset. <ul style="list-style-type: none"> — Check the programmed data and re-program it as necessary. Press TIMER again.
The cassette is ejected, power is shut off and "TIMER" and "☐☐" are blinking.	<ul style="list-style-type: none"> ■ This means that the end of the tape was reached while timer-recording was in progress. Therefore, the preset program may not be recorded in its entirety.

Other Problems?

Symptoms	Check points
Some channels are skipped over when scanning channels.	<ul style="list-style-type: none"> ■ Those channels are preset to be skipped over. If you need them, restore them. (☞ p. 11)
Channel cannot be changed.	<ul style="list-style-type: none"> ■ Is recording in progress? <ul style="list-style-type: none"> — Press the PAUSE button, change the channel, and press the PLAY button.
Snowy picture on screen when viewing TV programs while recording another program.	<ul style="list-style-type: none"> ■ Is the VIDEO indicator lit? <ul style="list-style-type: none"> — Press the TV/VIDEO button.
Remote control does not operate my TV.	<ul style="list-style-type: none"> ■ Although the provided remote control unit is compatible with JVC televisions as well as many TV models manufactured by others, it is possible that the provided remote control will not operate your TV, or in some instances, will have limited function capability. (☞ p. 31) ■ Is the remote control's VCR switch set to the left and the TV/CABLE switch set to "TV" ? <ul style="list-style-type: none"> — If not, set the VCR switch to the left and the TV/CABLE switch to "TV".
"12:00 AM" is blinking.	<ul style="list-style-type: none"> ■ This means the clock must be set. It's displayed when time-keeping is terminated due to a power failure or because the VCR's power plug was pulled from the AC outlet. To set the clock, ☞ p. 9. If power was interrupted, it's also likely that all preset timer programming data has been erased. Please check and re-program as necessary.

ATTENTION:

This recorder contains microcomputers. External electronic noise or interference could cause malfunctioning. In such cases, switch the power off and unplug the power cord. Then plug it in again and switch power on. Take out the cassette. After checking the cassette, operate the unit as usual.

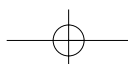

? If You Have Any Questions (cont'd)

Notes regarding...

Tuner Set

- Since receivable channels differ by locale, it will be necessary to reset your VCR's channels when you move to another location. Auto Channel Set is the easiest way to do this. ☞ p. 10

Playback

- If the end of the tape is reached during play or search, it is automatically rewound to the beginning and stops.
- The VCR automatically stops when the still mode is left activated for more than 5 minutes.
- If the still picture is unstable, use the VCR's CH -/+ buttons to correct the picture.
- During search playback, some noise bars will appear.
- If noise bars appear during playback or slow motion, correct using manual tracking. ☞ p. 17.
- There is no audio during search, slow, still, or frame-by-frame playback.
- When playing back LP recordings during search, still or frame-by-frame playback, the picture will be distorted, and there may be a loss of color.
- When a tape is first inserted, the recorder enters the automatic tracking mode automatically.
- During multi-speed search, some noise bars will appear.
- If adjacent index codes are too close to each other, Index Search may not function properly.
- If the cassette's safety tab has been removed, index codes cannot be marked or erased.
- You do not have to set to NORM when playing back tapes with normal sound track only.
- When MIX is selected, both "Hi-Fi" and "NORM" appear on the TV screen when the OSD button is pressed.

Recording

- To start recording with the VCR's Record button, press it once on its own. Pressing Record more than once activates Instant Timer Recording. ☞ p. 24.
- After pause, when recording is resumed, a few frames recorded before the pause may be overlapped by the new recording. This is meant to reduce picture distortion and is not a malfunction.
- The VCR automatically stops when record-pause continues for more than 5 minutes.
- If the end of the tape is reached while recording, it is automatically rewound to the beginning and stops.
- If the Record button does not work, check to see if the cassette's safety tab has been removed.
- The channel cannot be changed while recording is in progress. To change the channel, press Pause, then change the channel.

Timer-Recording

- When timer-recording is successfully completed, the VCR power is automatically switched off.
- If the end of tape is reached while timer-recording, the cassette is automatically ejected.
- Since the timer starts and stops recording based on the time being kept by the VCR's built-in clock, the clock's time must be accurate for correct timer-recording results.
- When you program the timer while viewing a program or a tape, the TV screen will show the on-screen menu but the audio will continue to be heard.
- You can also program the timer while the VCR is recording; the on-screen menu will not be recorded on tape.
- Although the provided Cable Box Controller is compatible with many different cable box brands, it is possible that it will not work with your cable box.

Remote TV Operation

- Whenever you replace batteries in the remote control, it is necessary to reset the TV code if your television is not a JVC TV.
- With some televisions, the TV/VIDEO button functions only to switch the TV to the VIDEO(AV) mode.
- Although the provided remote control unit is compatible with JVC televisions as well as many TV models manufactured by others, it is possible that the provided remote control will not work with your TV.

Remote Cable Box Operation

- Whenever you replace batteries in the remote control, it is necessary to reset the Cable Box code.
- Although the provided remote control unit is compatible with many different Cable Box brands, it is possible that the provided remote control will not work with your Cable Box.

Insert Editing

- To stop insert editing automatically, first determine the edit-out point on the recording tape (the end of the segment to be replaced) and press the remote control's C.RESET button. Then follow steps 8 through 11 in "Insert Editing" (☞ p.32); insert editing will stop automatically at the counter reading of 0:00:00.
- Insert editing cannot be started from a non-recorded segment.
- A small portion of the recording which precedes an insert edit may become erased.
- Video or audio insert cannot be performed if the safety tab is absent.
- Video or audio insert cannot be performed on a tape recorded at LP speed.
- Distortion may occur in the inserted video if the recording tape had discontinuous video or video recorded at different speeds.

Audio Dubbing

- When monitoring the sound during Audio Dubbing, the normal soundtrack will be automatically selected. If you wish to hear the mixed sound (Hi-Fi + normal soundtracks), ☞ p. 18.
- Audio dubbing is not possible with cassettes whose safety tab is absent.

Random Assemble Editing

- When editing, there may be a discrepancy of about 2 seconds on the playback tape between the locations you choose as cut-in/out points and the locations the VCR recognizes as those points.
- For any scene, the cut-out point must have a counter reading that is at least 1 second after the cut-in point. A cut-out point with a counter reading less than or the same as the cut-in point will not be registered.
- Since the playback deck prerolls during Random Assemble Editing, there must be at least 15 seconds worth of recorded material prior to any cut-in point on the playback tape.
- If the search time for a cut-in point exceeds 5 minutes, the recording deck's Record-Pause mode will be cancelled and editing will not take place.
- R.A.Edit is also possible with another JVC VCR which doesn't have a PAUSE terminal but does have an R.A.EDIT connector. In this case, connect both VCRs by their R.A.EDIT connectors.

Precautions

Please follow these safety precautions. Not doing so may result in damage to the VCR, remote control, or video cassette.

- Avoid extreme heat and direct sunlight.
- Avoid extreme cold.
- Avoid extreme humidity.
- Avoid dust.
- Avoid places subject to vibrations.
- Avoid strong magnetic fields.
- Do not block the VCR's ventilation openings.
- Do not place anything heavy on the VCR or remote control.
- Do not place anything which might spill on top of the VCR or remote control.
- Do not place the VCR on cushions, pillows, or thick carpeting.
- Use the VCR in a stable, horizontal position only.

Beware of moisture condensation

Moisture in the air will condense on the VCR when you move it from a cold place to a warm place, or under extremely humid conditions — just as water droplets form on the surface of a glass filled with cold liquid. Moisture condensation on the head drum will cause damage to the tape. In conditions where condensation may occur, keep the VCR's power turned on for a few hours to let the moisture dry.

When transporting

- Be sure to remove cassette from VCR before packing.
- Avoid violent shocks to the VCR during packing and transport.

Place cassettes in cassette cases and store vertically.

About head cleaning



Accumulation of dirt and other particles on the video heads may cause the playback picture to become blurred or interrupted. This model is equipped with a built-in head cleaner which automatically cleans the heads and reduces the likelihood of dirty heads. If blurred or interrupted playback pictures are displayed please consult the nearest JVC dealer.

Auto Head Cleaner

A built-in head cleaner automatically cleans the video heads and head drum whenever a tape is loaded or unloaded to reduce head clogging.

Specifications

GENERAL

Power requirement	: AC 120 V~, 60 Hz
Power consumption	: 21 W
Temperature	
Operating	: 5°C to 40°C (41°F to 104°F)
Storage	: -20°C to 60°C (-4°F to 140°F)
Operating position	: Horizontal only
Dimensions (WxHxD)	: 426 x 94 x 309 mm (16-13/16" x 3-3/4" x 12-3/16")
Weight	: 4.2 kg (9.3 lbs)
Format	: VHS NTSC standard
Maximum recording time	
(SP)	: 160 min. with T-160 video cassette
(EP)	: 480 min. with T-160 video cassette

VIDEO/AUDIO

Signal system	: NTSC-type color signal and EIA monochrome signal, 525 lines/60 fields
Recording/Playback system	: DA-4 (Double Azimuth) head helical scan system
Signal-to-noise ratio	: 45 dB
Horizontal resolution	: 240 lines
Frequency range	: 70 Hz to 10,000 Hz (Normal audio) 20 Hz to 20,000 Hz (Hi-Fi audio)
Input/Output	: RCA connectors (IN x 2, OUT x 1)

TUNER

Tuning system	: Frequency synthesized tuner
Channel coverage	
(VHF)	: Channels 2-13
(UHF)	: Channels 14-69
(CATV)	: 113 Channels
RF output	: Channel 3 or 4 (switchable; preset to Channel 3 when shipped) 75 ohms, unbalanced

TIMER

Clock reference	: Quartz
Program capacity	: 1-year programmable timer/ 8-programs
Memory backup time	: Approx. 10 min.

ACCESSORIES

Provided accessories	: RF cable (F-type), Infrared remote control unit, "AA" battery x 2, Cable Box Controller, Audio/Video cable, Mini-plug cable
----------------------	--

Specifications shown are for SP mode unless otherwise specified.
E. & O.E. Design and specifications subject to change without notice.

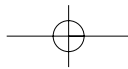

Operaciones básicas en español

Para las conexiones VCR-TV vea la hoja de la "Guía básica para las conexiones del VCR" adjunta a este manual de instrucciones.

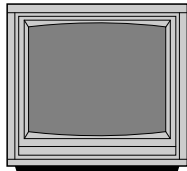

**ENCIENDA;
SELECCIONE EL CANAL
3 O 4 (O MODO AV)**

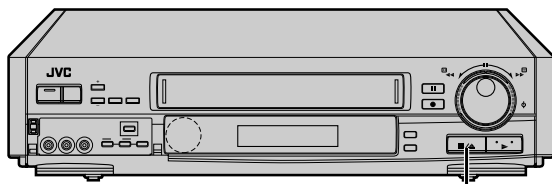

STOP/EJECT

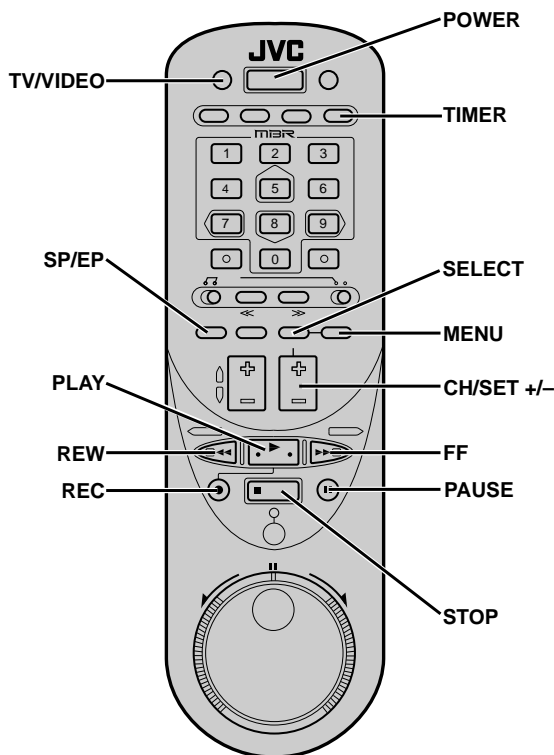

Disposición básica

Ajuste del reloj de su VCR y de la lengua para indicación en pantalla

1. Presione POWER para encender el VCR.
2. Presione TV/VIDEO para que aparezca "TV" del display del VCR.
3. Presione MENU.
4. Presione SET +/- para seleccionar "AJUSTE INICIAL", y luego presione SELECT.
5. Presione REW para seleccionar "ESPAÑOL" para indicación en pantalla.
6. Presione SET +/- para fijar el mes y luego presione SELECT.
7. Repita el paso 6 para ajustar el día, el año y la hora.



8. Presione MENU para comenzar de funcionamiento del reloj.

Asignación de canales al sintonizador de su VCR

1. Presione POWER para encender el VCR.
2. Presione TV/VIDEO para que aparezca "TV" del display del VCR.
3. Presione MENU.
4. Presione SET +/- para seleccionar "AJUSTE DE SINTONIZADOR", y luego presione SELECT.

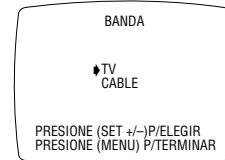
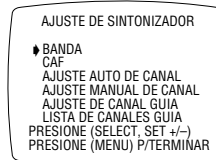

5. Presione SET +/- para seleccionar "BANDA", y luego presione SELECT.
6. Presione SET +/- para seleccionar "TV" o "CABLE".
 - Ajustelo en TV si su antena recibe sólo canales de UHF y VHF. Ajustelo en CABLE si su sistema de antena es una línea de TV por cable.
7. Presione MENU.
8. Presione SET +/- para seleccionar "AJUSTE AUTO DE CANAL", y luego presione SELECT.
 - Se inicia la sintonización automática de canales y después de completada la misma aparecerá en la pantalla el mensaje "FIN DE EXPLORACION".

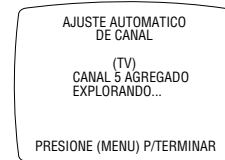
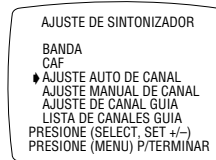

9. Presione MENU tantas veces como sea necesario.

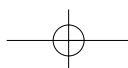

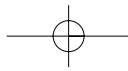

Reproducción básica

Preparación

- Encienda el televisor.
- Seleccione el canal 3 o 4 (o modo AV).

1. Inserte un cassette.
 - El VCR se encenderá automáticamente y el contador se repositionará a 0:00:00.
 - Si el cassette no tuviera lengüeta de seguridad, comenzará automáticamente la reproducción.
2. Presione PLAY para iniciar la reproducción.
3. Presione STOP para detener la reproducción.
 - Para rebobinar la cinta, presione REW.
 - Para avanzar rápidamente la cinta, presione FF.
 - Para detener el rebobinado o bobinado rápido, presione STOP.
4. Presione STOP/EJECT en el VCR para expulsar el cassette.

Grabación básica

Preparación

- Encienda el televisor.
- Seleccione el canal 3 o 4 (o modo AV).

1. Inserte un cassette con lengüeta de seguridad.
 - El VCR se encenderá automáticamente y el contador se repositionará a 0:00:00.
2. Presione CH +/- (o las teclas numéricas y luego ENTER) para seleccionar el canal que desea grabar.
3. Presione SP/EP para cambiar la velocidad de cinta.
4. Presione simultáneamente REC y PLAY para comenzar la grabación.
 - Para efectuar una pausa de grabación, presione PAUSE.
 - Para continuar con la grabación, presione PLAY.
5. Presione STOP para detener la grabación.

Para mirar un programa mientras graba otro

Durante la grabación...

1. Presione TV/VIDEO para que aparezca "VIDEO" del display del VCR.
 - La teledifusión que se está grabando desaparecerán.
2. Utilice los controles de canales del televisor para elegir otro canal que desee ver.
 - El programa seleccionado con los controles de canales de TV aparecerá en la pantalla del televisor mientras el programa seleccionado con los controles de canales del VCR se grabará en la cinta.

Grabación por temporizador

Preparación

- Encienda el televisor.
- Seleccione el canal 3 o 4 (o modo AV).

1. Inserte un cassette con lengüeta de seguridad.
 - El VCR se encenderá automáticamente y el contador se repositionará a 0:00:00.
2. Presione dos veces MENU, y luego presione SELECT.
 - Aparecerá el menú "PROGRAMA".

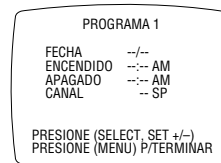

3. Presione SET +/- para seleccionar un número de programa vacante, y luego presione SELECT.
 - Inicialmente todos los programas están vacantes y el cursor está en el programa 1. Por lo tanto, presione simplemente SELECT.
4. Presione SET +/- para fijar el mes y luego presione SELECT.
5. Presione SET +/- para fijar el día del mes.
 - Para grabar un programa diario (lunes – viernes), presione DAILY (tecla 8). Para grabar un programa semanal, presione WEEKLY (tecla 9).
6. Presione SELECT.
7. Repita el paso 4 para fijar la hora de inicio, la hora de finalización, el número de canal y la velocidad de cinta.



8. Presione MENU tantas veces como sea necesario.
9. Presione TIMER.
 - El VCR se establecerá en el modo de grabación programada y se apagará.

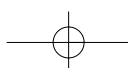

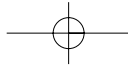

For Servicing

HOW TO LOCATE YOUR JVC SERVICE CENTER

TOLL FREE: 1-800-252-5722

Dear customer:

In order to receive the most satisfaction from your purchase, read the instruction booklet before operating the unit. In the event that repair is necessary, or for the address nearest your location, please refer to the factory service center list below or within the Continental United States, call 1-800-252-5722 for your authorized servicer. Remember to retain your Bill of Sale for Warranty Service.

— JVC

JVC SERVICE & ENGINEERING COMPANY OF AMERICA DIVISION OF US JVC CORP.

FACTORY SERVICE CENTER LOCATIONS

107 Little Falls Road
Fairfield, NJ 07004-2105
(201) 808-9279

1500 Lakes Parkway
Lawrenceville, GA 30243-5357
(404) 339-2522

705 Enterprise Street
Aurora, IL 60504-8149
(708) 851-7855

5665 Corporate Avenue
Cypress, CA 90630-0024
(714) 229-8011

10700 Hammerly, Suite 110
Houston, TX 77043-2310
(713) 935-9331

2969 Mapunapuna Place
Honolulu, HI 96819-2040
(808) 833-5828

230 Eliot Street
Ashland, MA 01721-2377
(508) 881-5923

14505 Commerce Way
Miami Lakes, FL 33016-1512
(305) 362-6252

890 Dubuque Avenue
South San Francisco, CA 94080-1804
(415) 871-2666

Sophisticated electronic products may require occasional service. Just as quality is a keyword in the engineering and production of the wide array of JVC products, service is the key to maintaining the high level performance for which JVC is world famous. The JVC service and engineering organization stands behind our products.

NATIONAL HEADQUARTERS
JVC SERVICE & ENGINEERING COMPANY OF AMERICA
DIVISION OF US JVC CORP.
107 Little Falls Road
Fairfield, NJ 07004-2105

If you ship the product...

Pack your JVC unit in the original carton or one of equivalent size and strength. Enclose, with the unit, a letter stating the problem or symptom that exists and also a copy of the receipt or bill of sale you received when you purchased your JVC unit. Print your home return address on the outside and the inside of the carton. Send to the appropriate JVC Factory Service Center as listed above.

Don't service it yourself.

CAUTION

To prevent electrical shock, do not open the cabinet. No user serviceable parts inside. Refer servicing to qualified service personnel.

ACCESSORIES

To purchase accessories for your JVC product, you may contact your local JVC Dealer. Or from the 48 Continental United States call toll free: 1-800-882-2345.

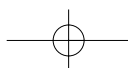

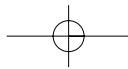

Warranty

LIMITED WARRANTY		CONSUMER VIDEO 1-90
<p>JVC COMPANY OF AMERICA warrants this product and all parts thereof, except as set forth below ONLY TO THE ORIGINAL PURCHASER AT RETAIL to be FREE FROM DEFECTIVE MATERIALS AND WORKMANSHIP from the date of original retail purchase for the period as shown below. ("The Warranty Period")</p>		
PARTS	1 YR	LABOR 90 DAYS
<p>THIS LIMITED WARRANTY IS VALID ONLY IN THE FIFTY (50) UNITED STATES, THE DISTRICT OF COLUMBIA AND IN COMMONWEALTH OF PUERTO RICO.</p> <p>WHAT WE WILL DO: If this product is found to be defective, JVC will repair or replace defective parts at no charge to the original owner. Such repair and replacement services shall be rendered by JVC during normal business hours at JVC authorized service centers. Parts used for replacement are warranted only for the remainder of the Warranty Period. All products and parts thereof may be brought to a JVC authorized service center on a carry-in basis except for Television sets having a screen size 25 inches and above which are covered on an in-home basis.</p> <p>WHAT YOU MUST DO FOR WARRANTY SERVICE: Return your product to a JVC authorized service center with a copy of your bill of sale. For your nearest JVC authorized service center, please call toll free: (800) 252-5722.</p> <p>If service is not available locally, box the product carefully, preferably in the original carton, and ship, insured, with a copy of your bill of sale plus a letter of explanation of the problem to the nearest JVC Factory Service Center, the name and location of which will be given to you by the toll-free number.</p> <p>If you have any questions concerning your JVC Product, please contact our Customer Relations Department.</p> <p>WHAT IS NOT COVERED: This limited warranty provided by JVC does not cover:</p> <ol style="list-style-type: none"> 1. Products which have been subject to abuse, accident, alteration, modification, tampering, negligence, misuse, faulty installation, lack of reasonable care, or if repaired or serviced by anyone other than a service facility authorized by JVC to render such service, or if affixed to any attachment not provided with the products, or if the model or serial number has been altered, tampered with, defaced or removed; 2. Initial installation and installation and removal for repair; 3. Operational adjustments covered in the Owner's Manual, normal maintenance, video and audio head cleaning; 4. Damage that occurs in shipment, due to act of God, and cosmetic damage; 5. Signal reception problems and failures due to line power surge; 6. Video Pick-up Tubes/CCD Image Sensor, Cartridge, Stylus (Needle) are covered for 90 days from the date of purchase; 7. Accessories; 8. Batteries (except that Rechargeable Batteries are covered for 90 days from the date of purchase);from the date of purchase); <p>There are no other express warranties except as listed above.</p> <p>THE DURATION OF ANY IMPLIED WARRANTIES INCLUDING THE IMPLIED WARRANTY OF MERCHANTABILITY, IS LIMITED TO THE DURATION OF THE EXPRESS WARRANTY HEREIN.</p> <p>JVC SHALL NOT BE LIABLE FOR THE LOSS OF USE OF THE PRODUCT, INCONVENIENCE, LOSS OR ANY OTHER DAMAGES, WHETHER DIRECT, INCIDENTAL OR CONSEQUENTIAL (INCLUDING, WITHOUT LIMITATION, DAMAGE TO TAPES, RECORDS OR DISCS) RESULTING FROM THE USE OF THIS PRODUCT, OR ARISING OUT OF ANY BREACH OF THIS WARRANTY. ALL EXPRESS AND IMPLIED WARRANTIES, INCLUDING THE WARRANTIES OF MERCHANTABILITY AND FITNESS FOR PARTICULAR PURPOSE, ARE LIMITED TO THE WARRANTY PERIOD SET FORTH ABOVE.</p> <p>Some states do not allow the exclusion of incidental or consequential damages or limitations on how long an implied warranty lasts, so these limitations or exclusions may not apply to you. This warranty gives you specific legal rights and you may also have other rights which vary from state to state.</p>		
JVC COMPANY OF AMERICA DIVISION OF US JVC CORP.		41 Slater Drive Elmwood Park, New Jersey 07407

REFURBISHED PRODUCTS CARRY A SEPARATE WARRANTY, THIS WARRANTY DOES NOT APPLY. FOR DETAILS OF REFURBISHED PRODUCT WARRANTY, PLEASE REFER TO THE REFURBISHED PRODUCT WARRANTY INFORMATION PACKAGED WITH EACH REFURBISHED PRODUCT.

For customer use:	
Enter below the Model No. and Serial No. which is located either on the rear, bottom or side of the cabinet. Retain this information for future reference.	
Model No.: _____	Serial No.: _____
Purchase date: _____	Name of dealer: _____

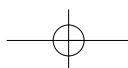

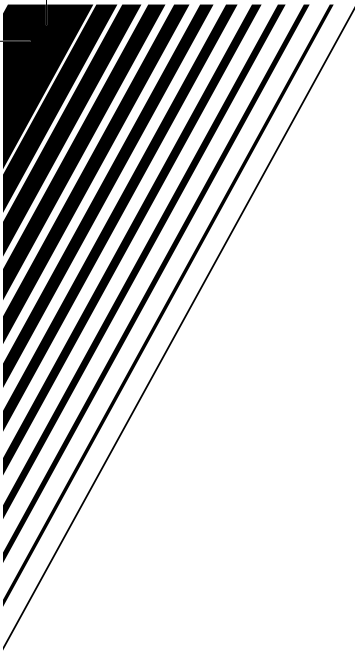
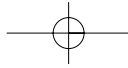

HR-IP820U

JVC

JVC COMPANY OF AMERICA
DIVISION OF US JVC CORP.
41 Slater Drive, Elmwood Park, N.J. 07407

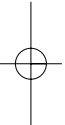
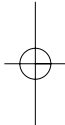

U.S. PATENTS		
4034276	4092684	4829419
4064537	4120583	4896260
4068257	4121284	4942576
4079412	4178606	4954951
4091426		
Canada Patented (Breveté), 1979, 1980		

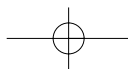

JVC

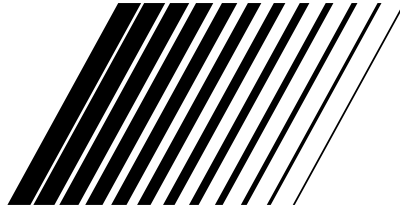

INDEX Plus+ System

HR-IP820U

INDEX Plus+ System

Video Tape Indexing and Management System

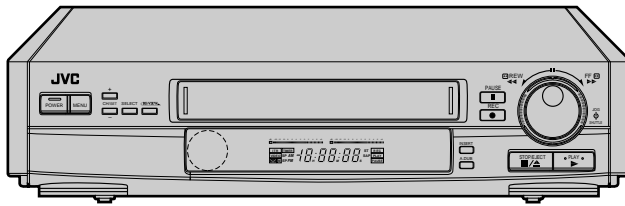

INDEX *Plus+*TM



INSTRUCTIONS

Contents

There are two instruction manuals for the HR-IP820U—

- This one for the HR-IP820U INDEX Plus+ system
- The other one for the HR-IP820U VCR functions

Please refer to both manuals when operating the HR-IP820U.

System Outline3
 Introduction3
 Information Screens.....3

INDEX Plus+ Button Functions4

Preparing To Use INDEX Plus+5
 Download Function Setting5
 Preferred Channel Selection.....8
 INDEX Plus+ Initial Settings8

Receiving Broadcasts10
 Information From Host Station10
 Download Data10
 Download Schedule.....10

Channel-Related Information
— Practical Use Of CSPG —.....11
 Displaying Channel-Related Information.....11
 Using Channel-Related Information For
 Timer Recording.....11

Program-Related Information (PRI)
— Practical Use Of PRI —.....12
 Displaying PRI12
 Storing/Erasing Of PRI12

About Cassettes13
 Tape Types13
 Reading The Tape13

Recording.....14
 Setting The Cable Box Channel Number.....14
 Setting The Tape Number.....14

Finding A Program16
 Selecting A Program From A Directory.....16
 To View And Select Programs From The
 Directories Of Other Tapes16
 Searching For A Program16
 Title Search.....17
 Tape Number Search.....18

Revising/Erasing Directories19
 Title Changes19
 Tape Number Changes20
 Erasing A Directory.....21
 Deleting Information From A Directory21

Retroactive Indexing22
 Consolidating Program Names23
 Uploading A Directory.....23

**Reading A Directory From A
 PR Tape25**

Other Convenient Functions26
 Transferring Directories26
 Disabling INDEX Plus+ Functions28
 Re-enabling INDEX Plus+ Functions.....28
 Initializing The Library.....29
 Confirming Status Of Back-Up.....30

Restoring Lost Data31
 Error Messages32

Helpful Terms And Information33

Troubleshooting34

The messages on all on-screen displays appear in English only.

For information on the non-INDEX Plus+ functions, refer to the separate HR-IP820U instruction manual. INDEX Plus+ can be disabled if required (refer to page 9 of this instruction manual).

VCR PLUS+, PLUSCODE and INDEX PLUS+ are trademarks of Gemstar Development Corporation. VCR PLUS+ and INDEX PLUS+ Systems are manufactured under license from Gemstar Development Corporation and Index Systems, Inc.

System Outline

Introduction

INDEX Plus+ is a video tape indexing and management system that gives you:

1. Random access to programs you have recorded,
2. An easy way to organize your video library, and
3. Simplified timer recording.

INDEX Plus+ also enables automatic setting of time and date.

For programs recorded using the HR-IP820U, program data is automatically stored in the VCR's memory. Tapes made using a non-INDEX Plus+ VCR can be indexed retroactively, and their index data will also be stored in the deck's memory. This allows you to create a video library, providing both organization and quick, precise access to all programs.

The Program data is obtained from a host channel. The host channel transmits the program schedule and channel identification for broadcast and cable TV stations. This is called Channel Specific Program Guide data (CSPG). Program Related Information (PRI) for the program currently being received may also be sent by the TV station broadcasting the program. In some cases a non-host station may send its own program schedule (CSPG).

INDEX Plus+ is an inherently flexible system. For example, when you initiate a search for a particular program, there are multiple options from which the VCR can choose. It selects the method that will most quickly and accurately find the program, depending on the type of tape used (see page 13 for details on tape types).

Information Screens

Channel Related Information Screen

These screens display various types of information which can include the date and time, channel number, channel name, name of program and time remaining of the program currently being received (refer to page 10 of this instruction manual).

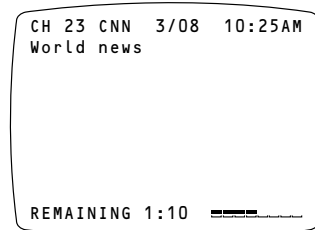

Channel Specific Program Guide (CSPG) Screen

Programming schedules from host broadcasting stations are also made available by INDEX Plus+ (refer to page 10 of this instruction manual). The necessary operations, as described later in this manual, can be performed simply and in a relatively short time.

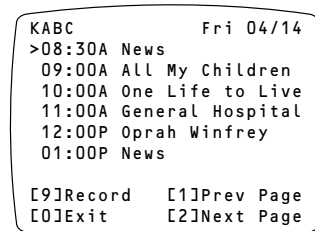

Program Related Information (PRI) Screen

Depending on the program, you may also have access to certain information (PRI) related to a program being broadcast (refer to page 11 of this instruction manual). This information could be in the form of stats of one of the players in a baseball game, a recipe from a cooking show, or questions and answers from a quiz show or educational program.

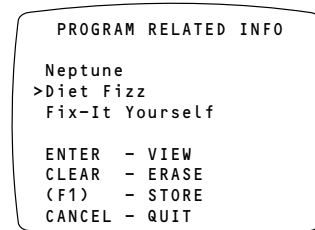

NOTE: Video publishing using INDEX Plus+ is a future possibility. Education, exercise, cooking and karaoke are potential themes. The videos may be released as video books or magazines, separated according to subject or category.

INDEX Plus+ Button Functions

HR-IP820U Remote Control Unit

TITLE (Pg. 11)
Displays name of program, current channel's programming schedule.

INDEX Plus+ (Pg. 16)
Displays current tape's directory.

PAGE
Displays previous or following page of current directory; displays previous or following tape's directory.

ENTER
Follow on-screen instructions for use of this button.

SEARCH << >>
Moves cursor to beginning of title (<<) or end (>>) at REVISE TITLE screen.

CURSOR
REW scrolls LEFT; FF scrolls RIGHT; VOL+ moves cursor UP; VOL- moves cursor DOWN during INDEX Plus+ operation screens.

JOG (Pg. 19)
Enters letters and numbers at the REVISE TITLE screen. Press the JOG/SHUTTLE button when using the JOG dial for this purpose.

CLEAR
Follow on-screen instructions for use of this button.

INFO (Pg. 12)
Displays information related to program currently being received.

DIGIT
Enter tape number and program name while a directory is displayed.

PRINT FOR FUTURE USE

CANCEL
Follow on-screen instructions for use of this button.

FUNCTION
Follow on-screen instructions for use of these buttons.

SET
SET+ moves cursor UP; SET- moves cursor DOWN when preparing to use INDEX Plus+.

Preparing To Use INDEX Plus+

Before you can receive CSPG (Channel-Specific Programming Guide) data from a host station, or reference tapes or programs using INDEX Plus+, you must perform the following procedure.

Before continuing . . .
 Refer to pages 8 – 12 of the HR-IP820U's instruction manual and perform the following procedures:

- Connection
- Tuner Setting
- Cable Box Controller Setting (if a Cable Box is used)

Download Function Setting

What is "downloading"? With INDEX Plus+, it means receiving CSPG data from the host station and storing it in your VCR's internal memory. When required this data can be accessed. The host station receives information from regular and cable TV broadcasters and sends this information along with its own as CSPG data. The host station sends information around the clock, even late at night when most VCRs aren't in use. This gives you access to new information on a daily basis.

Preparation

1. Turn on the power to the TV and the VCR.
 * If you use a cable box, turn on its power.
2. Set the TV to the channel or mode appropriate for video playback.

Procedure

Download Function Confirmation

- 1 Press MENU as many times as necessary to select "MAIN MENU".
- 2 Press SET to select "SET-UP MENU", then press SELECT.

- 3 Press SET to select "DOWNLOAD FUNCTION SET-UP", then press SELECT. The screen to the right appears:

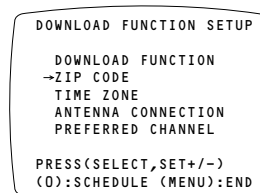

NOTE: The "ANTENNA CONNECTION" option only appears here when the "CABLE BOX OUTPUT" at the CABLE BOX SET screen is set to "OFF". (Refer to page 13 of the HR-IP820U instruction manual.)

- 4 Press SET to select "DOWNLOAD FUNCTION", then press SELECT. The screen to the right appears:

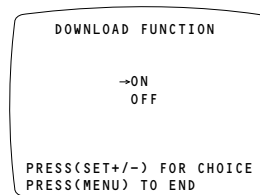

- 5 Press SET to select "ON", then press MENU. The DOWNLOAD FUNCTION SET-UP screen reappears.

NOTE: If you decide you don't want to receive CSPG from the host station, select "OFF" at the DOWNLOAD FUNCTION confirmation screen.

Inputting Zip Code

- 6 Press SET to select "ZIP CODE", then press SELECT. The next screen looks like this:

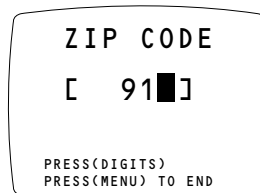

- 7 Using the DIGIT buttons, input the zip code (up to 5 digits) of the area in which the VCR is being used. To make corrections, press CLEAR to delete the digit farthest to the right. Once the incorrect digit has been deleted, enter the correct one.
- 8 Press MENU. The DOWNLOAD FUNCTION screen reappears.

ATTENTION
 If you input a zip code following host station scanning, all download data will be lost.

Continued on next page.

Preparing To Use INDEX Plus+ (cont'd)

Setting Time Zone

9 Press SET to select "TIME ZONE", then press SELECT. The following screen appears:

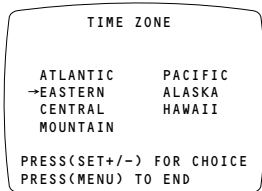

10 Press SET to select the time zone in which the VCR is being used.

11 Press MENU. The DOWNLOAD FUNCTION SETUP screen reappears.

Antenna Connection Confirmation (when a cable box is not connected)

If you use a cable box, go to step **15**.

12 Press SET to select "ANTENNA CONNECTION", then press SELECT. The following screen appears:

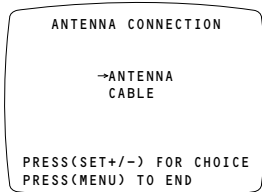

13 Press SET to select either "ANTENNA" or "CABLE", depending on the connection of your VCR.

14 Press MENU. The DOWNLOAD FUNCTION SETUP screen reappears.

Host Station Download Scanning

15 Press MENU. The following screen appears:

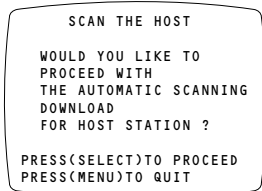

If yours is an antenna connection, go to step **16 a**.
If yours is a cable box connection, go to step **16 b**.

16 a Press SELECT, and scanning begins.

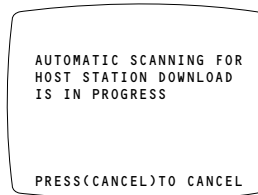

When the host station is located, the Guide Channel settings for VCR Plus+ timer recording are performed automatically. (Refer to page 15 of the HR-IP820U's instruction manual.) Press CANCEL to quit the process.

16 b Press SELECT. The following screens appear:

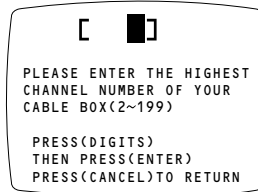
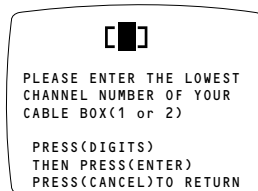

Using the DIGIT buttons, input the lowest channel number available on your cable box and press ENTER. Then, input the highest channel number available on your cable box and press ENTER to initiate scanning. (To correct your entry before pressing ENTER, press CLEAR. The right-most digit will be deleted first.) (If you do not know the lowest and highest channel numbers available on your cable box, enter "1" for the lowest channel and "199" for the highest channel number.)

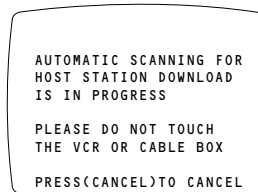

When the host station is located, the Guide Channel settings for VCR Plus+ timer recording are performed automatically. (Refer to page 15 of the HR-IP820U's instruction manual.) Press CANCEL to quit the process.

17 When the host station scan and Guide Channel set are successfully completed, the screen to the right appears. Press CANCEL to return to the normal screen.

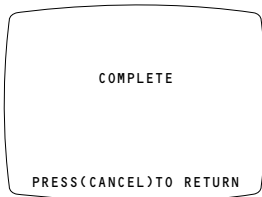

NOTES:

- CSPG data is not available after Host Station Download Scanning until the CSPG data has been downloaded from the host station. CSPG can be received later at the next "Download Schedule" time. (Refer to "Download Data" and Download Schedule" on page 10.)
- The Host Station Download Scanning function may take less than 10 minutes, or more than 45 minutes, to complete. During host station scanning, host station scanning messages will be displayed on screen on a blue background.
- The scanning time will depend on a number of factors, including whether you are using an antenna or a cable connection, the number of channels you receive and whether or not changes to the channel map need to be made.
- If the host station cannot be located through scanning, the screen to the right appears. If this happens, press CANCEL, wait a short while, then re-perform the procedure from step **1**.



- If using a cable connection . . .

. . . the display to the right appears superimposed on the TV picture during guide channel setting. Press CANCEL to quit the process.

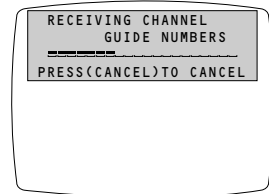

. . . if there is more than one host station in your area, the following screen may appear during guide channel setting. If it does, note the station name(s) appearing on the left side of the screen. Select the cable system on which you receive the station(s) by pressing REW (left) or FF (right). Then press MENU. Guide channel setting then continues.

	CABLE	B	C	D	E	F	
Station name	A&E	15	25	30	52	81	Cable system
	FAM	--	12	18	--	221	Channel number
	WGN	53	115	25	33	511	
	CNN	102	10	34	88	75	
	TNN	23	45	--	105	151	
	WXYZ	125	1	10	20	30	
	SELECT CABLE SYSTEM(A-I)						
	WITH(REW/FF) THEN (MENU)						

As many as 6 station names and 9 cable systems (A – I) can be displayed.

EXAMPLE

If you receive A&E on channel 25, FAM on channel 12, WGN on channel 115, CNN on channel 10, TNN on channel 45 and WXYZ on channel 1, . . .

1. Press REW or FF to select "C". "C" begins blinking.
2. Press MENU.

- If Guide Channel data could not be obtained, the screen to the right appears. If this happens, perform the setting manually (refer to page 15 of the HR-IP820U's instruction manual).

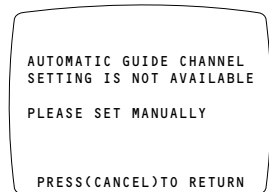

Preparing To Use INDEX Plus+ (cont'd)

Preferred Channel Selection

Your VCR can receive program title and CSPG data from as many as 25 different stations. Select the stations from which you want to receive this data.

Preparation

1. Turn on the power to the TV and the VCR.
2. Set the TV to the channel or mode appropriate for video playback.
3. Perform the Download Scanning procedure (see page 6).

Procedure

1 Press MENU twice. The Main Menu screen appears.

2 Press SET to select "SET-UP MENU", then press SELECT.

3 Press SET to select "DOWNLOAD FUNCTION SETUP", then press SELECT. The screen to the right appears:

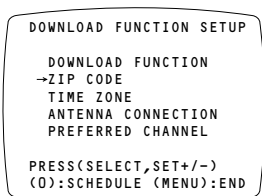

4 Press SET to select "PREFERRED CHANNEL", then press SELECT. The following screen appears:

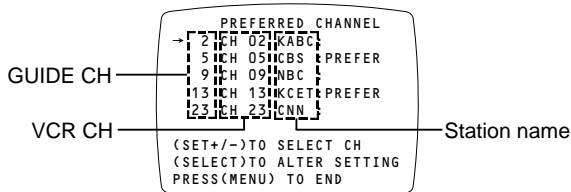

NOTE: If you haven't yet performed the Download Scanning procedure, the screen to the right appears:

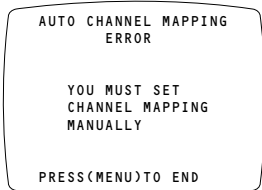

Go to page 6 and perform the Host Station Download Scanning procedure, then return to step **1** on this page and begin the Preferred Channel Selection procedure.

5 Press SET to choose a channel from which you want to receive CSPG data, then press SELECT. "PREFER" appears on the right side of the screen. Repeat the procedure for each desired channel (the maximum being 25).

NOTES:

- If the station name is not displayed, you cannot make that a preferred channel.
- If a non-preferred channel is sending its own CSPG, you can obtain the data.

INDEX Plus+ Initial Settings

The HR-IP820U, using download data from the host station, sets its own clock automatically. The set-up procedure is described below.

Also explained in this section is the selection procedure for end-of-program options.

Preparation

1. Turn on the power to the TV and the VCR.
2. Set the TV to the channel or mode appropriate for video playback.

Procedure

Automatic Clock Set

1 Press MENU **twice** to select "MAIN MENU".

2 Press SET to select "SET-UP MENU", then press SELECT.

3 Press SET to select "INDEX PLUS+ INITIAL SET", then press SELECT. The screen to the right appears:

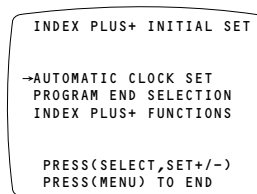

NOTE: In the INDEX Plus+ INITIAL SET screen, the INDEX PLUS+ FUNCTIONS option does not appear during recording.

4 Press SET to select "AUTOMATIC CLOCK SET", then press SELECT. The screen to the right appears:

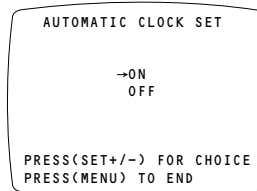

5 Press SET to select either "ON" or "OFF". Selecting ON allows automatic clock setting, while choosing OFF disables the function.

NOTES:

- When AUTOMATIC CLOCK SET is enabled, the clock's accuracy may vary slightly, depending on the data received from the host station.
- The INDEX Plus+ memory backup allows the memory to remain active for 24 hours without power. In the event of a power failure, or if the power cord is unplugged, as long as power is restored to the VCR within 24 hours of the initial outage, the clock is automatically set regardless of the selection you made in step **5**. If you don't restore power to the VCR within 24 hours, the clock returns to its initial setting ("AM 12:00" blinking).

6 Press MENU. The INDEX PLUS+ INITIAL SET screen appears.

Program End Selection

Program end selection allows you to choose whether the tape should continue to play or stop after your playback selection has finished. The selection made before playback starts cannot be overridden. Even if you access the screen below and change the setting after playback begins, the change has no effect.

- 7 Press SET to select "PROGRAM END SELECTION", then press SELECT. The screen to the right appears:

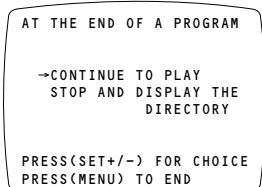

- 8 Press SET to select either "CONTINUE TO PLAY" or "STOP AND DISPLAY THE DIRECTORY". CONTINUE TO PLAY means that, when the end of a program is reached on an HR, PR or RI tape, playback of the next program begins automatically. If you only want to watch the selected program, select STOP AND DISPLAY THE DIRECTORY. Once the selected program ends, the tape's directory appears. (If the selected program ends near the end of the tape, the directory may not appear.)

- 9 Press MENU. The INDEX PLUS+ INITIAL SET screen reappears.

INDEX PLUS+ Functions Setting

Using the INDEX Plus+ Functions screen, the INDEX Plus+ system can be disabled.

The INDEX Plus+ functions default setting is "ON". To disable INDEX Plus+, perform the following steps:

- 10 Press SET to select "INDEX PLUS+ FUNCTIONS", then press SELECT. The screen to the right appears:

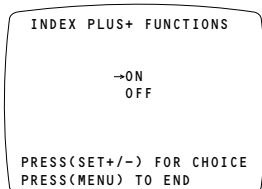

- 11 Press SET to select "OFF". INDEX Plus+ is now disabled.
- 12 Press MENU as many times as necessary to return to the normal screen.

ATTENTION

When combining the contents of several tapes recognized by this VCR's library into one tape, make sure that you set INDEX PLUS+ FUNCTIONS to ON and use this VCR as the recorder. If you record with INDEX PLUS+ FUNCTIONS set to OFF, or if you use a non-INDEX Plus+ VCR as the recorder, you must set INDEX PLUS+ FUNCTIONS to OFF to playback on this VCR, or problems will arise in the library.

Receiving Broadcasts

Information From Host Station

When you choose to view a program from the host broadcasting station (or from a preferred channel after downloading), certain related information will be displayed if it is sent by the host station. To confirm whether or not the host station is sending information, perform the procedure described below.

Preparation

1. Turn on the power to the TV and the VCR.
2. Set the TV to the channel or mode appropriate for video playback.

Procedure

- 1 Press TITLE. If the information is available from the host station, this display appears:

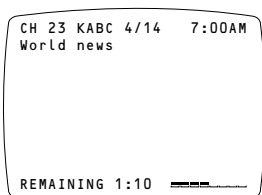

If the host station is not sending the information, the display looks like this:

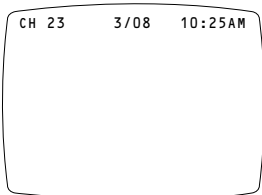

NOTES:

- Depending on the program, the time remaining in the program may not be displayed.
- If a cable box is connected and in use, the channel number will not be displayed.
- If you press TITLE during recording or playback, the appropriate screen from step 1 appears. However, during playback, the remaining time, date and time indications do not appear. (During playback, the channel number, station name and program title may not appear.)

Download Data

Using INDEX Plus+, you can receive data such as CSPG data from the host station. The host station sends CSPG data up to 4 times a day. If your TV is turned on and set either to the video channel or its AV mode, the display above appears to inform you that data will be received:

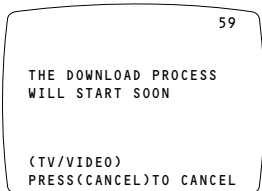

The number in the upper right hand corner of the screen indicates the time remaining (in seconds) until data reception begins. If you don't want the data, press CANCEL. ("... OR CABLE BOX" only appears if you're using a cable box.) During reception of download data, the screen above appears:

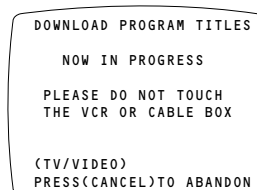

To stop reception of data in progress, press CANCEL.

* If using a cable box to receive cable channels, the cable box power must be on in order to download data from host station.

To watch a TV broadcast during reception of download data...

- If using the RF connection, press the TV/VIDEO button so that the VCR's VIDEO indicator goes out.
- If using the AV connection, change the TV's input mode from AV to TV.
- If using a cable box, it is not possible to view cable box channels during the reception of download data. Then use the channel selector on the TV to select the channel you wish to view.

ATTENTION

- Download CSPG data cannot be received when the VCR's power is on. In order to receive download CSPG data, the VCR's power must be off during a scheduled download period. Remember to turn the VCR off when it's not in use. If you pressed CANCEL to stop reception, the command is only effective until the VCR is turned on and off again. Then the VCR begins receiving data again (if it's being transmitted).
- Once data reception ends, you can view CSPG. (Refer to page 11 of this instruction manual.)

Download Schedule

Once the host station scan is completed, you can access the download schedule for data.

Procedure

- 1 Follow the instructions under "Download Function Confirmation" on page 5 for accessing the DOWNLOAD FUNCTION SETUP screen.

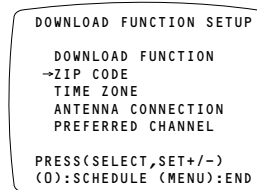

- 2 Press "0" and the DOWNLOAD SCHEDULE screen appears.

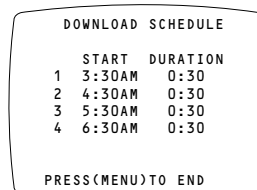

- 3 Press MENU twice to return to the normal screen.

Channel-Related Information

— Practical Use Of CSPG (Channel-Specific Programming Guide) —

If the host broadcasting station is sending channel-related information, INDEX Plus+ allows you to access that information. Comprehensive program listings for many channels can be displayed on screen. Using this data, you can easily program the HR-IP820U to record shows you select from the displayed listings.

Displaying Channel-Related Information

Preparation

1. Turn on the power to the TV and the VCR.
2. Set the TV to the channel or mode appropriate for video playback.

Procedure

- 1 Select a channel using the CH +/- button. Then press TITLE. The screen looks like this:

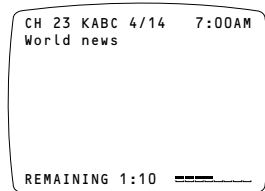

- 2 While the above screen is displayed, press TITLE. The programming guide for the selected channel appears. (Guides may not be available for certain channels.)

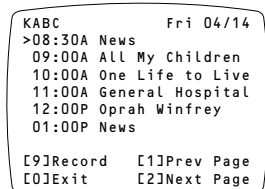

If the guide consists of more than one page, press "2" to view the following page. Pressing "1" returns you to the previous page. To return to the normal screen, press "0".

NOTE: If a cable box is connected, the following screen appears:

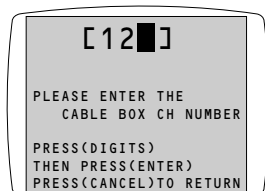

Using the DIGIT buttons, input the channel number selected on the cable box and press ENTER.

Select a program by placing the cursor next to it using the CURSOR button (VOL +/-). Then press ENTER, and information pertaining to the selected program (start and end times, etc.) is displayed. To return to the programming guide, press "3".

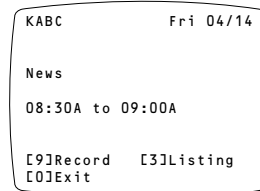

- 3 To remove the display from the screen, press "0".

Using Channel-Related Information For Timer Recording

Preparation

1. Turn on the power to the TV and the VCR.
2. Set the TV to the channel or mode appropriate for video playback.
3. Insert a cassette.

Procedure

** Perform steps 1 and 2 from the preceding procedure.

- 1 Once the programming guide for the selected channel has appeared, place the cursor next to the program you want to record by pressing the CURSOR button (VOL +/-). Then press "9". The recording confirmation screen appears.

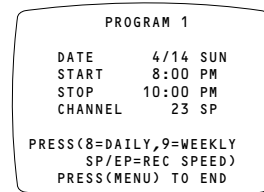

- 2 Select the recording speed by pressing the SP/EP button.
- 3 Press MENU. Set the AUTO TIMER function (refer to page 30 of the HR-IP820U instruction manual for details).
- 4 Press MENU again.
- 5 Press TIMER. The VCR enters the TIMER mode, and its power is turned off automatically.

Program-Related Information (PRI)

— Practical Use Of PRI —

With INDEX Plus+, information related to the program currently being received can be displayed on screen. This information may take the form of a player's stats in a baseball game, recipes or techniques from a cooking show, or even questions and answers from an educational program.

There are three types of PRI — regular PRI, "instant" PRI, and "auto pop-up" PRI.

NOTE: Not every program contains PRI data.

Displaying PRI

Preparation

1. Turn on the power to the TV and the VCR.
2. Set the TV to the channel or mode appropriate for video playback.

Procedure

- 1 Select a channel using the CH +/- button. The screen looks like this:

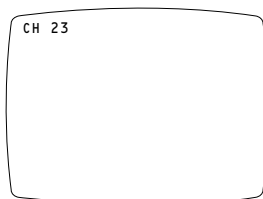

- * To display regular PRI — step 2
- * To display instant PRI — step 3
- * To display auto pop-up PRI — Auto pop-up PRI will be automatically displayed when it is transmitted.

- 2 Press INFO. The PRI index appears.

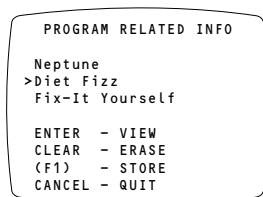

Using the CURSOR button (VOL +/-), place the cursor next to the title representing the information you want to see. Then press ENTER. The selected information appears on screen.



- 3 An icon appears in the upper right corner of the screen to tell you that instant PRI is being received (such as in the screen on the left):

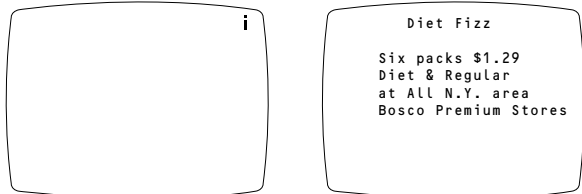

Press INFO, and the selected program-related information appears.

- 4 To return to the normal screen, press INFO again. Or don't press any button, and the display returns automatically.

Storing/Erasing of PRI

You can store regular PRI in the VCR's internal memory, which allows you to recall it at a later time. The stored data can also be erased, should you decide you don't need it anymore.

Storing Procedure

- 1 Select a channel using the CH +/- button.
- 2 Press INFO. The PRI index appears. Place the cursor next to the title representing the information you want to store.
- 3 To save the data, press F1. A "#" appears to the right of the selected title.
- 4 Press CANCEL to return to the normal screen.

Erasing Procedure

- 5 To erase stored data, access the PRI index and place the cursor next to the title representing the information you want to erase. Then press CLEAR.
- 6 Press CANCEL to return to the normal screen.

NOTES:

- PRI data is constantly being saved in the VCR's internal memory, and as the memory fills up, older data is erased. To guarantee storage of desired information, perform the above procedure.
- The VCR's internal memory capacity is fixed. If you press F1 to store data but the "#" doesn't appear, that means there's no more space in memory. Before you can store new data, you must first erase some older data.

About Cassettes...

INDEX Plus+ System recognizes three different types of tapes. In order to ensure the most effective use of INDEX Plus+, familiarize yourself with the three tape classifications.

Tape Types

Home-recorded tape (HR): A tape recorded on the HR-IP820U or a similar INDEX Plus+ VCR. The index is written and updated for each program, and in this case stored in the deck's memory, at the time of recording.

Pre-recorded tape (PR): Unlike tapes currently on the market, PR tapes contain a directory input by the video publisher. You can access the directory using your INDEX Plus+ VCR.

Retroactively-indexed tape (RI): A tape that was recorded on a non-INDEX Plus+ VCR. You can use INDEX Plus+ to add an index.

Reading The Tape

Preparation

1. Turn on the power to the TV and the VCR.
2. Set the TV to the channel or mode appropriate for video playback.

Procedure

In order to determine the tape type, the VCR automatically goes into PLAY mode for a few seconds after the tape is inserted.



This screen appears while the tape is being read.

One of the following screens appears, depending on the results:

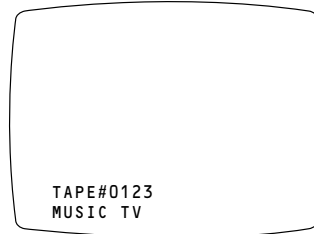

The VCR was able to successfully read the tape.

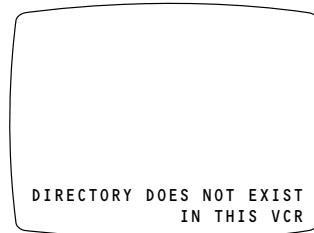

The tape was successfully read, but no directory exists for it in memory.

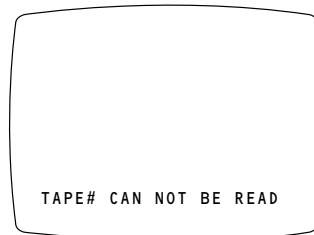

The tape is new, or could not be read.

NOTE: If the safety tab has been removed from the cassette, playback begins automatically.

Recording

Setting The Cable Box Channel Number

After the record mode is initiated, the cable box channel number must be set if a cable box is in use. The screen will ask for the cable box channel number.

Procedure

- 1** Enter the cable box channel number using the DIGIT keys.
- 2** Press ENTER.

Setting The Tape Number

After recording has been initiated, the VCR must know the Tape Number before the data can be stored in memory. If you know the number but the VCR can't read it, you need to enter it. When using a brand new tape, you have to command the VCR to assign a Tape Number for you. The procedure differs slightly depending on the situation.

Preparation

1. Turn on the power to the TV and the VCR.
2. Set the TV to the channel or mode appropriate for video playback.

Procedure

- 1 a** Insert a tape. If the screen to the right appears (when using a new tape or one recorded on a non-INDEX Plus+ VCR), continue from step **2**.

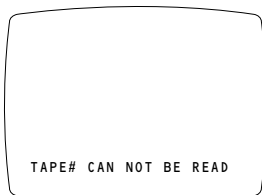

ATTENTION:

- When using an RI tape, if the screen in step **1 a** appears, skip to step **3**.
- If you use a tape that already has a Tape Number and has been recorded on, but has not been entered in the library, the screen in step **1 a** appears. Skip to step **3**.
- In the event that you press STOP at the "READING TAPE# . . ." screen, stopping Tape Number reading partway through . . .
 . . . if the inserted tape has not yet been assigned a Tape Number, go to step **2**.
 . . . if the inserted tape has already been assigned a Tape Number, go to step **3**.

- b** Insert a tape. If the screen to the right appears (as when using a tape that already has a Tape Number and has been entered), skip to step **4**.

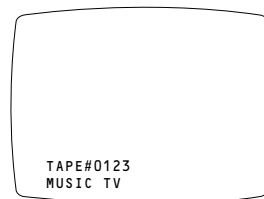

- c** Insert a tape. If the screen to the right appears (as when using a tape that has a directory which is not recognized by your VCR), skip to step **5**.

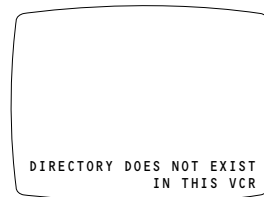

- 2** Start recording. The screen to the right appears:

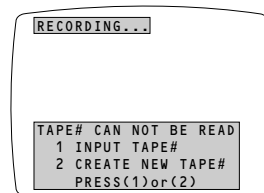

Press 2, or don't press either 1 or 2. The new Tape Number is automatically assigned. Go to step **6**.

- 3** Start recording. The screen to the right appears:

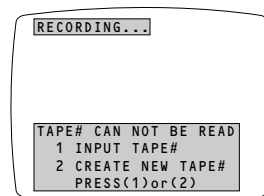

Press 1.

The screen to the right appears:

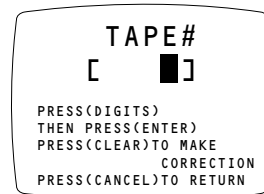

Use the DIGIT buttons to enter the Tape Number. (To make corrections to the number you've entered, press CLEAR and input the correct number. To quit the process, press CANCEL and the previous screen reappears.) Once the correct number has been input, press ENTER.

Continued on next page.

If the number you entered is not in the VCR's memory (if you made a mistake), the screen to the right appears:

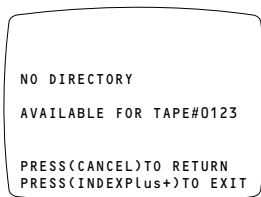

Press CANCEL, or wait a few seconds, and the TAPE # screen reappears. Reinput the Tape Number. Go to step 6.

ATTENTION

If you don't input the Tape Number within 1 minute after the first screen in step 3 first appears, a Tape Number will automatically be assigned. That means that tape will have two numbers. Be sure to input your Tape Number as soon as possible.

4 Start recording. Since a Tape Number has already been assigned, no further operations are necessary.

5 Start recording. A Tape Number is automatically assigned. Go to step 6.

6 Once recording is finished, press STOP/EJECT to take the tape out. When ejecting a tape for which you've just entered a tape number, or a tape to which a number has just been automatically assigned, the display to the right appears:

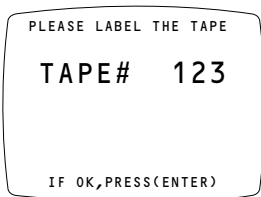

IMPORTANT

Before you press ENTER to clear the screen, write the tape number (if newly assigned or not recorded) on the tape label. This will help to eliminate accidents and confusion later.

NOTES:

- If the recording time is particularly short, the data may not register in the library and a tape number may not be assigned.
- When recording onto a VHS-C cassette using a cassette adapter, a directory is not made. Even if it were, the program times would not be accurate, and the VCR would not be able to find the program start points.
- When recording over a tape made on another INDEX Plus+ VCR, old directories remain. This may inhibit the making of new directories.

- During recording, if you press INDEX Plus+, the Tape Number, tape position and program title appear on screen (if the VCR was able to read the Tape Number, tape position and program title).
- After recording ends, "PLEASE WAIT A MOMENT" appears on screen for a few seconds. No operations can be performed until the message disappears.

INFORMATION:

In the case of a tape that has accidentally been assigned multiple Tape Numbers, perform the following consolidation procedure:

1. Insert the tape, and the VCR reads the Tape Number at the current tape position. (Refer to page 13 of this instruction manual.)
2. Find a location on the tape where another Tape Number is recognized, play the tape back for a few seconds and press INDEX Plus+.
3. The directory appears, and program titles that appeared separately under different Tape Numbers are combined into one listing, under the older number.
4. If the tape has more than two Tape Numbers, repeat steps 2 and 3 for each additional number.

ATTENTION:

When this VCR's memory becomes full, you cannot register any more directories. Be sure to occasionally check the status of memory. When it becomes full, cancel unnecessary directories. (Refer to "Erasing A Directory" on page 21 of this instruction manual.)

Use the following procedure to check the status of memory.

1. Turn on the power to the TV and the VCR.
2. Set the TV to the channel or mode appropriate for video playback.
3. Insert an HR tape.
4. Press INDEX Plus+. The tape's directory appears.
5. Press F3.
6. The screen to the right appears. At the bottom of the screen, the amount of memory currently being used is shown. It begins blinking when there's no memory space open.

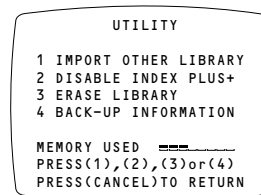

Finding A Program

Selecting A Program From A Directory

The first thing you need to do is to insert the tape. Then call up its directory. How soon it appears depends on the type of tape on which the desired program is recorded.

Preparation

1. Turn on the power to the TV and the VCR.
2. Set the TV to the channel or mode appropriate for video playback.

- If you're using an HR tape recorded on your INDEX Plus+ VCR, the directory is already stored in the VCR's memory and is quickly accessible. Press INDEX Plus+ to display the directory.
- If the program you want to watch is on an HR tape that was recorded on a different INDEX Plus+ VCR, the directory must be uploaded before it can be displayed. (See page 23.)
- PR tapes recorded using INDEX Plus+ have their directories written directly on them. Press INDEX Plus+. A short time is required before the directory can be displayed.

Each time you press , the screen changes as shown.



Once the directory appears, you can make your selection. Using the CURSOR button (VOL+/-), place the cursor next to the name of the program you want to watch, and press PLAY. The VCR begins searching the tape for the program's start point, and playback begins once it's found.

If you press STOP, the tape stops at the start point of the program.

Press INDEX Plus+ to return to the normal screen.

NOTES:

- The * in the screen above shows the tape's current position. (The * only appears when the VCR is able to detect the position of the tape.)

- The → indicates that the entire title is not displayed. To view the entire title, press the REW and FF buttons.
- If the recording speed was changed during a program, -- appears. (Recorded time is calculated as though the program were recorded entirely in EP mode.)
- The displayed length of each program is approximate.
- If there is a blank space of more than 5 minutes on the tape, BLANK SPACE appears on screen.

To View And Select Programs From The Directories Of Other Tapes

Preparation

1. Turn on the power to the TV and the VCR.
2. Set the TV to the channel or mode appropriate for video playback.
3. Insert an HR tape into the VCR.

Procedure

- 1 Press INDEX Plus+.
- 2 The tape's directory appears. To view the directories of other tapes stored in the VCR's memory, press < (DIGIT "7") or > (DIGIT "9").

Searching For A Program

There are two ways to search for a program. You can use TITLE search, where you tell the VCR to find your program using its name, or TAPE # search, where the VCR uses the Tape Number of the tape containing the desired program.

Your search starts from one of two situations:

- ① A tape is already in the machine, and you decide you want to watch another program, but you're not sure where it is.
- ② There's no tape in the machine, and you want the VCR to find the program you want to watch.

In either case, you need to access the FIND screen. In the first situation, press INDEX Plus+ to call up the directory of the inserted tape, then press F1. If there's no tape inserted, pressing INDEX Plus+ brings up the FIND screen.

The procedures for each method are explained in the following pages.

Title Search

- Follow the instructions in the box on page 16 for accessing the FIND screen. (If there's no tape inserted, the message "NO CASSETTE" appears on this screen.)

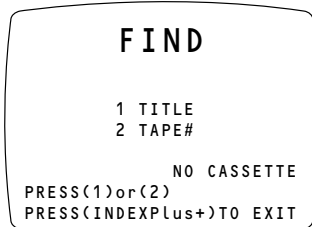

- Press "1" to bring up the TITLE screen, or press INDEX Plus+ to quit the process.

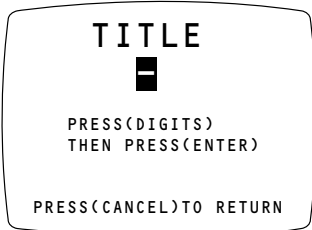

- At the TITLE screen, use the DIGIT buttons to enter the first letter of the name of the program you're trying to find. Each DIGIT button (excluding "0") represents 2 or 3 letters. The letters represented by each button appear to the left of the button.

A
B
C



When you press a button, the numeric digit of the button appears first. If you press the button again the button's top letter appears. If you want to input the second or third letter, press the button again. Continuing to press the button will initiate the same cycle again. When you're done, press ENTER. Pressing CANCEL returns you to the previous screen.

NOTE: You can view the list programs from the very beginning (alphabetically). To do so, press ENTER at the TITLE screen without inputting a title.

- A list of programs appears, names to the left and Tape Numbers to the right, with the one you selected at the top. Make sure the cursor is next to it.

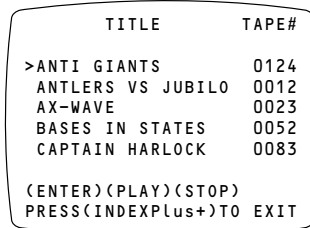

- If you press ENTER, the directory of the tape containing the selected title appears.

- If you press PLAY or STOP . . .

① If the tape containing the selected title is already in the VCR, the tape either stops at the beginning of the selected program or starts playback from that point.

② If there is no tape in the VCR, the following screen appears:

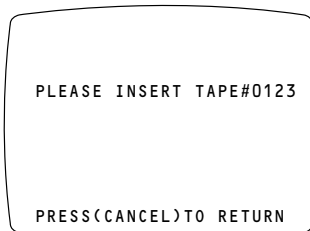

Insert the correct tape and the VCR automatically begins searching for the program. If you press CANCEL, the first screen from step 4 reappears.

③ If a tape not containing the selected title is in the VCR, the following screen appears (if the VCR was able to read the Tape Number, "THIS IS TAPE#xxx" appears on the screen):

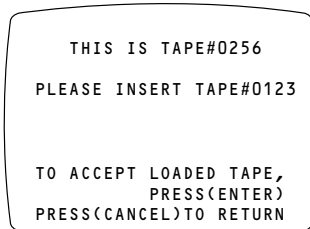

Replace the inserted tape with the correct tape and the VCR begins its search automatically. If you press CANCEL, the normal screen reappears.

Continued on next page.

Finding A Program (cont'd)

NOTE: If you press PLAY or STOP while the directory appears, and for some reason the VCR cannot find the program you selected on the inserted tape, the following screen appears to tell you this. Re-perform the procedure from step **1**.

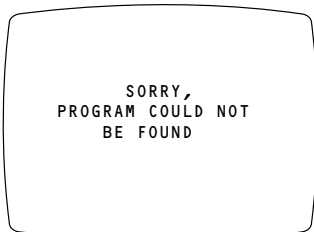

Tape Number Search

In this case the VCR uses the Tape Number to find the desired program. All tapes recorded on an INDEX Plus+ VCR, and those indexed using INDEX Plus+, have Tape Numbers.

1 Follow the instructions in the box under "Searching For a Program" on page 16 to access the FIND screen.

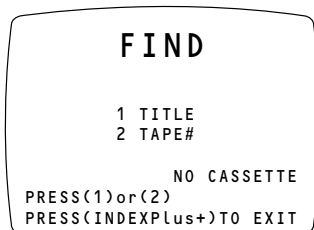

Press 2.

2 The TAPE# screen appears.

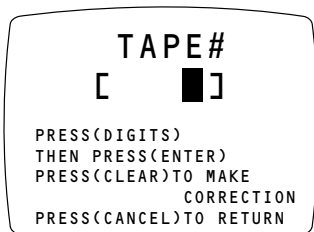

Input the Tape Number using the DIGIT buttons. Press CLEAR to make corrections, or CANCEL to quit the process. Once the number is input, press ENTER.

3 a If the number you input is not in the VCR's memory, the following screen appears:

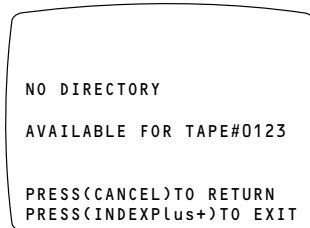

Press CANCEL to return to the TAPE# screen, then perform step **2** again.

3 b If the number you input is accepted, the directory corresponding to the Tape Number you entered appears. Insert the correct tape and, after selecting the desired program using the CURSOR button (VOL +/-), press PLAY or STOP. Continue on to step **4**.

4 The following screen appears to let you know the VCR is searching the tape for your program:

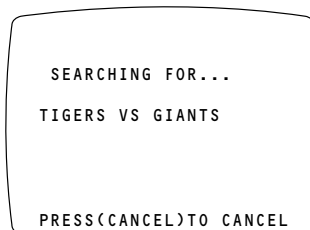

5 Normally the VCR finds your program quickly and starts playback from the beginning of the selected program, or stops at that point.

NOTE: If you press PLAY or STOP while the directory appears, and for some reason the VCR cannot find the selected program on the inserted tape, the following screen appears to tell you this. Re-perform the procedure from step **1**.

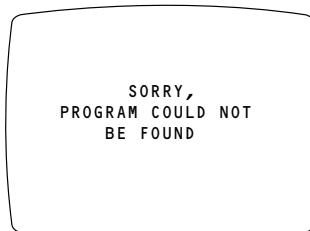

Revising/Erasing Directories

In addition to entering various information into directories, you can change Title and Tape Number information. You can also erase an entire directory you don't need anymore, or when you need to clear memory space for new directories.

Preparation

1. Turn on the power to the TV and the VCR.
2. Set the TV to the channel or mode appropriate for video playback.

The process begins from the "REVISE" screen, and the method for accessing this screen depends on whether or not there's a tape in the machine.

- ① If a tape is already inserted, press INDEX Plus+ to access its directory, and press F2.
- ② If no tape is loaded, press INDEX Plus+ and the FIND screen (page 17) appears. Press 2 (TAPE#) and enter the Tape Number of the tape with the directory you want to revise. Then press ENTER, and that tape's directory appears. Press F2 to bring up the REVISE screen.

The procedures for revising/erasing directories are explained in the following pages.

Title Changes

Procedure

- 1 Follow the instructions in the box above for accessing the REVISE screen. When it appears, press 1.

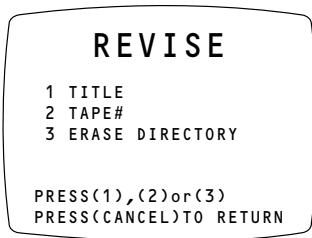

- 2 The REVISE TITLE screen appears.

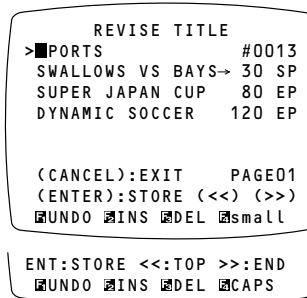

Here you can make changes to any or all of the program names. A flashing frame appears on the first letter of the first title. Move the frame by pressing the CURSOR buttons (REW = LEFT, FF = RIGHT, VOL+ = UP, VOL- = DOWN). Place the frame on the letter you want to change and input the new letter using the DIGIT buttons. Then press ENTER to store. Pressing CANCEL returns you to the REVISE screen.

NOTES:

- Pressing ENTER stores the change and moves the cursor to the next line, or you can press the CURSOR button (VOL+/-) to move the cursor, and the change is automatically stored.
- You can move to a different page by pressing CH +/-.
- Press SEARCH << to move the cursor to the beginning of the title, or SEARCH >> to move it to the end.
- As each of the other DIGIT keys represents multiple letters, the "0" key represents multiple symbols. The following symbols can be input by pressing the "0" button. By repeatedly pushing the "0" button the symbols can be selected in the following order: 0, !, ", #, \$, %, &, ', (,), *, +, ,, -, /, :, <, =, >, ?, @, [, \,], ^, _, ` {, |, }, ~.

Letters and numbers can be input using the JOG dial on the remote control. When using the JOG dial for this purpose, press the JOG/SHUTTLE button on the remote control so the light illuminates.

The use of the each of the FUNCTION buttons (F1-F4) is as follows:

- F1 (UNDO):** If, after inputting a new title, you find you changed the wrong one or you decide to change it again, press F1 before storing. The original title returns.
- F2 (INS):** If you realize that you neglected to input a letter in the title, or if you want to insert a space, press F2. A blank space is inserted at the location of the frame. You can then input a new letter if you wish.
- F3 (DEL):** Pressing F3 deletes the letter highlighted by the frame.

Continued on next page.

Revising/Erasing Directories (cont'd)

F4 (CAPS/small): Program titles can be made to appear in all capital letters, all lower-case letters, or a combination of the two. The default setting is capital. To change a letter to lower case, place the frame on it and press **■** (PAUSE). Press **■** (PAUSE) again to change it back to a capital letter. To input a lower-case letter, press F4 (noting that "small" has changed to "CAPS" at the bottom of the screen) and then input the letter.

NOTES:

- The function of F4 displayed is always the opposite of the form of a letter you input.
EX. If you input a letter when "CAPS" is displayed, the letter will be lower case.
- Press CLEAR to delete the previous letter.
- To copy a title, press PLAY when the cursor is next to that title. Then move the cursor to the location where the copied title is to be placed and press STOP. The new title supercedes the previous one.

Once you've made all desired changes, press ENTER and the directory reappears.

Tape Number Changes

Procedure

- 1** Follow the instructions in the box in the first section of page 19 for accessing the REVISE screen. When it appears, press 2.

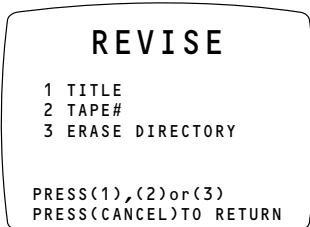

- 2** The TAPE# screen appears.

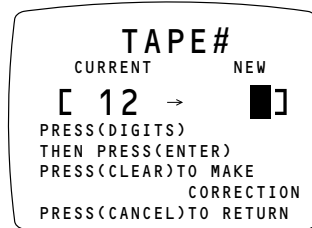

Under "CURRENT", the number of the tape whose directory you accessed appears automatically. (See NOTE at the end of this page.) The frame appears to the far right, under "NEW". Input the new Tape Number using the DIGIT buttons. Press CLEAR to make corrections, or CANCEL to quit the process. Once the number is input, press ENTER.

- 3** If the new number you input is already assigned to another tape, the screen looks like this:

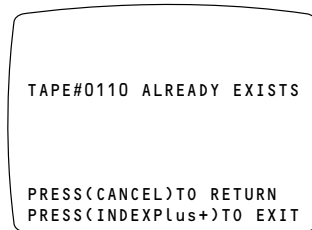

Wait a few seconds, or press CANCEL, to return to the TAPE# screen.

If the new number you input is accepted, the directory reappears, with the new Tape Number displayed in the top right portion of the screen.

NOTE: At the TAPE# screen, you can change the CURRENT number. However, if you are not exactly sure of the contents of the tape represented by that number, you are advised to access that tape's directory and confirm the contents before changing the number. If the number you input under "CURRENT" is not in memory, a screen appears to tell you this. Wait a few seconds, or press CANCEL, to return to the TAPE# screen.

Continued on next page.

Erasing A Directory

If one of your tapes is no longer going to be used, you can erase its directory from memory, creating space for another.

- 1 Follow the instructions in the box in the first section of page 19 for accessing the REVISE screen. When it appears, press 3.

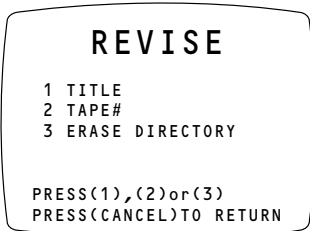

- 2 The ERASE DIRECTORY screen appears.

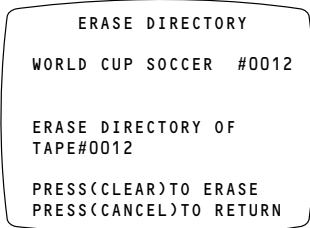

Check the names of the programs listed to be sure you want to erase this directory. To erase, press CLEAR. Or press CANCEL to return to the REVISE screen.

- 3 Pressing CLEAR brings up the following screen:

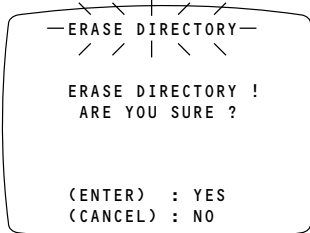

For safety's sake, INDEX Plus+ offers you one last chance to change your mind. If you are unsure, select "NO" by pressing CANCEL. The REVISE screen reappears. If you're sure you want to erase this directory, select "YES" by pressing ENTER.

- 4 If you chose to erase the directory, the following screen appears:



Wait a few seconds, or press any button, and you return to the normal screen.

Deleting Information From A Directory

Normally, when you record from the middle of a tape, dubbing over a previously-recorded show, the directory is updated automatically. However, if anything remains from the program you're recording over (ex. a portion of a commercial), the VCR may continue to recognize this as a single program, and not erase it from the directory. If this happens, follow this procedure to erase the data of the old program:

- 1 Access the inserted tape's directory by pressing INDEX Plus+.
- 2 Using the CURSOR button (VOL+/-), place the cursor next to the name of the program you've recorded over, and press CLEAR. That program name begins to blink. While it's blinking, press ENTER. Press CANCEL at any time to quit the process.

If you pressed ENTER, the program name is replaced by "BLANK SPACE". If the program was less than 5 minutes in length, however, the program name disappears and all programs listed underneath it move up one space each.

Retroactive Indexing

Tapes recorded on another VCR can be indexed, and this index data can be added to the HR-IP820U's library. Tapes to which an index has been added are known as RI (Retroactively-Indexed) tapes. To make an RI tape, perform the procedure described below.

ATTENTION

To make an RI tape, the VCR must be able to read Index Marks at the start of each program. If the VCR on which you recorded this tape didn't write these marks on the tape, you need to enter them manually. (See page 20 of the HR-IP820U's instruction manual.)

Preparation

1. Turn on the power to the TV and the VCR.
2. Set the TV to the channel or mode appropriate for video playback.
3. Insert the tape you want to make into an RI tape.

Procedure

- 1** Press INDEX Plus+. The screen to the right appears:

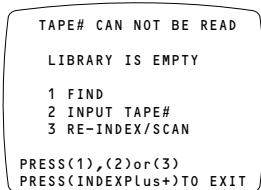

Press 3.

NOTE: If your VCR's library is empty, 1 and 2 will not appear and LIBRARY IS EMPTY appears on screen.

- 2** The screen to the right appears:

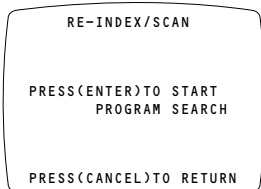

Press ENTER. If the tape was not at the beginning, the VCR rewinds it to that point. Then it begins searching for programs.

- 3** The following screens appear:

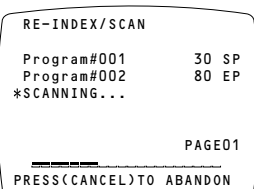
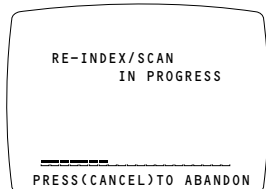

"RE-INDEX/SCAN" changes to "SEARCHING TITLE..." or "SEARCHING PROGRAM..." when each index mark is found.

To quit the process, press CANCEL.

- Pressing CANCEL at the first screen in step **3** returns you to the normal screen.
- Pressing CANCEL at the second screen in step **3** brings up the following confirmation screen:

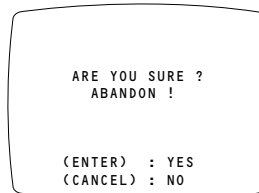

If you are sure you want to stop, select "YES" by pressing ENTER. The normal screen appears. If you decide not to abandon the process, select "NO" by pressing CANCEL. The above screens reappear, and RE-INDEX/SCAN continues.

When the RE-INDEX/SCAN is complete, the VCR rewinds the tape to the beginning.

- 4** The next screen looks like this:

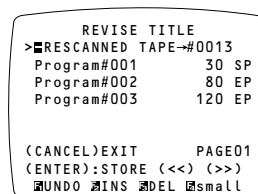

The Tape Number is automatically set by the VCR. Using the DIGIT and CURSOR buttons (VOL +/-, REW, FF), input a name for each program.

When you're done, press INDEX Plus+ and the normal screen returns.

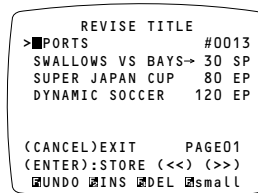

- 5** Press STOP/EJECT to take the tape out. When ejecting a tape to which a number has just been automatically assigned, the screen to the right appears:

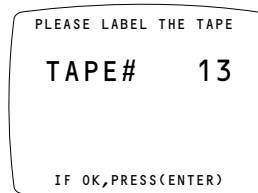

IMPORTANT

Before you press ENTER to clear the screen, write the tape number on the tape label. The tape number will not be recorded on a Retroactively Indexed tape. Therefore it will be necessary to enter this tape number whenever this cassette is inserted in the VCR.

- 6 To view the directory of an RI tape later, insert the tape and press INDEX Plus+. The screen from step 1 appears. Press 2, then input the Tape Number. (Be careful not to input an incorrect Tape Number.)

NOTES:

- If the tape has been recorded over several times, Index Marks may remain and RE-INDEX/SCAN may not be successful. Erase the Index Marks manually (refer to pg. 20 of the HR-IP820U instruction manual.)
- If Retroactive Indexing is unsuccessful, "FAILURE" appears on screen in step 3. Re-perform the procedure from step 1.
- Retroactive Indexing may occasionally be unsuccessful, depending on the condition of the tape.

Consolidating Program Names

If the tape you want to index contains Index Marks in locations other than the start points of the programs, a "ghost" program may appear on the directory. If this should happen, consolidate the names according to the procedure that follows.

Procedure

- 1 After step 3 on page 22 (under "Retroactive Indexing"), press CANCEL.

- 2 The next screen looks like this:

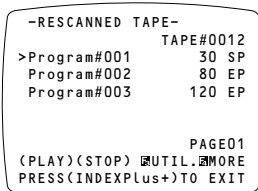

Select the programs to be consolidated using the CURSOR button (VOL +/-). (If you're consolidating, for example, programs 2 and 3, place the cursor next to program 3.) Then press CLEAR.

- 3 A screen like this one appears:

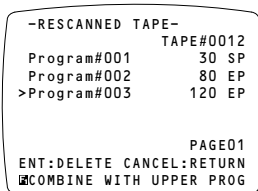

Press F1.

- 4 The screen now looks like this:

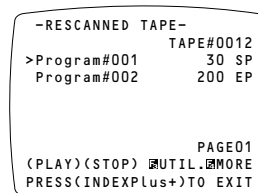

Press F2 and then 1.

Using the DIGIT and CURSOR buttons (VOL +/-, REW, FF), input the program name.

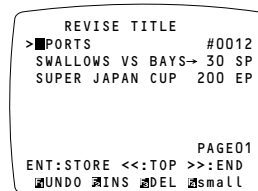

Press INDEX Plus+ and the normal screen reappears.

NOTE: If you consolidate programs that were recorded at different tape speeds (SP/EP), -- appears. The program time is calculated as though the program were recorded entirely in EP mode.

Uploading A Directory

You can load the directory of a tape which you previously removed from your library, or of a tape recorded on another INDEX Plus+ VCR, into your VCR's memory.

Preparation

1. Turn on the power to the TV and the VCR.
2. Set the TV to the channel or mode appropriate for video playback.
3. Insert the tape with the directory you want to load/reload.

Procedure

- 1 Press INDEX Plus+. The screen to the right appears (if the library is empty, FIND is replaced by RESTORE):

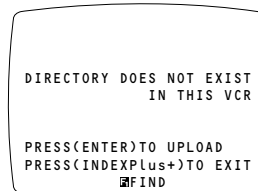

Press ENTER. If the tape was not at the beginning, the VCR automatically rewinds it to that point before starting its search for programs.

Retroactive Indexing (cont'd)

2 The following screens appear:

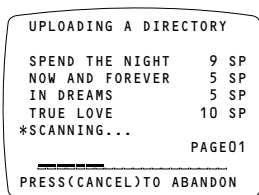
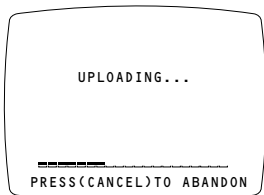

During the process, "UPLOADING A DIRECTORY" is followed on screen by "SEARCHING TITLE..." and then "SEARCHING PROGRAM..." when each index mark is found.

To quit the process, press CANCEL.

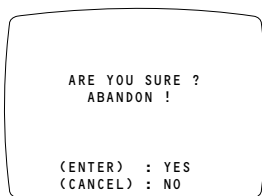

- Pressing CANCEL at the first screen in step **2** returns you to the normal screen.
- Pressing CANCEL at the second screen in step **2** brings up the confirmation screen above:

If you are sure you want to stop, select "YES" by pressing ENTER. The normal screen appears. If you decide not to abandon the process, select "NO" by pressing CANCEL. The screens in step **2** reappear and uploading continues.

When the search is complete, the VCR automatically rewinds the tape to the beginning.

3 The next screen looks like this:

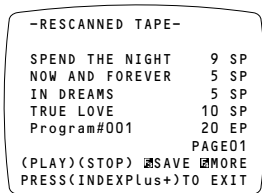

Press F3.

4 The screen to the right appears:

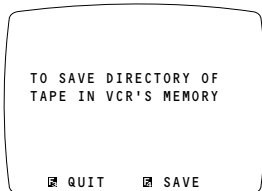

To save the directory in the VCR's library, press F4. Or press F3 to return to the previous screen.

5 Once you press F4, a new tape number is assigned and the screen to the right appears:

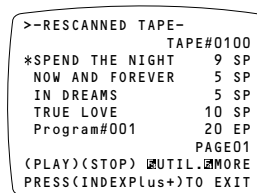

The tape's directory is now stored in the VCR's library. To return to the normal screen, press INDEX Plus+.

6 Press STOP/EJECT to take the tape out. When ejecting a tape to which a number has just been automatically assigned, the screen to the right appears:

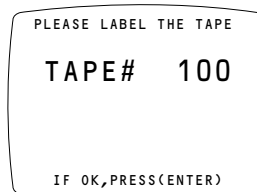

IMPORTANT

Before you press ENTER to clear the screen, write the tape number on the tape label. This will help to eliminate accidents and confusion later.

NOTES:

- If the tape has been recorded over several times, Index Marks may remain and uploading may not be successful. Erase the Index Marks manually (refer to pg. 20 of the HR-IP820U instruction manual).
- If uploading was not successful, "FAILURE" appears on screen. Re-perform the procedure from step **1**.
- If a particular program title could not be read, "PROGRAM#..." appears.
- Uploading may occasionally be unsuccessful, depending on the condition of the tape.

Reading A Directory From A PR Tape

Your VCR can read the directory of a PR (pre-recorded) tape and store it in the library.

Preparation

1. Turn on the power to the TV and the VCR.
2. Set the TV to the channel or mode appropriate for video playback.
3. Insert a PR tape.

Procedure

1 Press INDEX Plus+. The following screens appear:

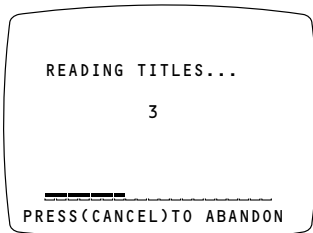

The number at the center of the screen shows the number of titles that have been read.

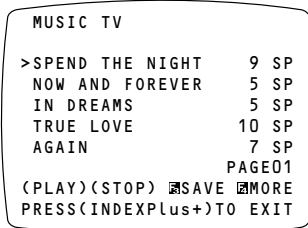

Press F3.

2 The following screen appears:

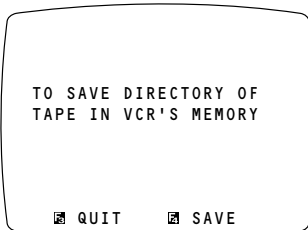

To save the PR tape's directory in the VCR's library, press F4. Or press F3 to return to the previous screen.

3 Once you press F4, a new tape number is automatically assigned and the following screen appears:

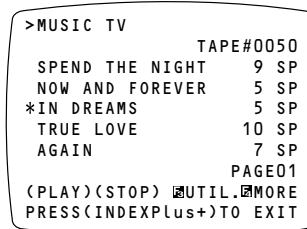

The PR tape's directory is now stored in the VCR's library.

To return to the normal screen, press INDEX Plus+.

4 Press STOP/EJECT to take the tape out. When ejecting a tape to which a number has just been automatically assigned, the following screen appears:

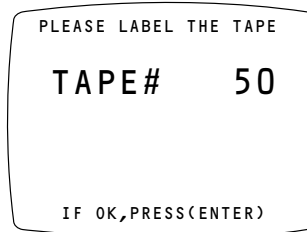

IMPORTANT

Before you press ENTER to clear the screen, write the tape number on the tape label. This will help to eliminate accidents and confusion later.

NOTES:

- If the VCR cannot read the directory, "FAILURE" appears on screen. Re-perform the procedure from step **1**.
- Depending on the condition of the tape, the VCR may not be able to read the directory.

Other Convenient Functions

You can transfer directories from one machine to another (if you own 2 INDEX Plus+ VCRs), make a back-up tape containing all directories in memory, and disable INDEX Plus+.

Transferring Directories

If you have two INDEX Plus+ VCR's, you can copy the entire group of directories from one VCR to the other. Then you can watch your tapes and benefit from INDEX Plus+ features on either VCR.

Preparation

1. Turn on the power to the TV and the VCR.
2. Set the TV to the channel or mode appropriate for video playback.
3. Confirm the back-up status of the data you want to transfer, then write down the back-up tape's Address Number and Program Number. (Program Number may not exist.)
4. Initialize the VCR's library (refer to page 29 of this instruction manual).
5. Insert the back-up tape for the second VCR. (To restore your VCR's library, insert its back-up tape.)

Procedure

1 Press INDEX Plus+.

2 The screen to the right appears:

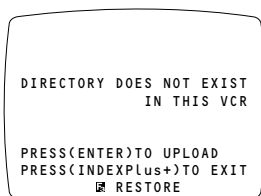

Press F3.

2 The screen to the right appears:

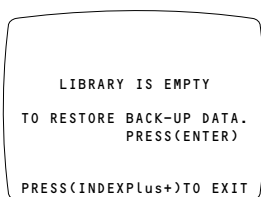

Press ENTER.

4 The following screen appears:

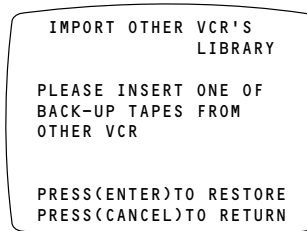

Press ENTER.

5 The RESTORE ADDRESS screen appears.

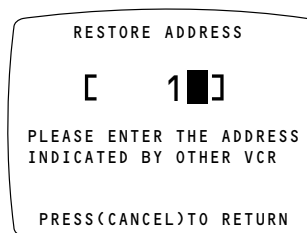

Using the DIGIT buttons, input the Address Number of the back-up tape. Then press ENTER.

NOTE: If you press ENTER without having input the back-up tape's Address Number, the VCR asks you if you want to read the data from the current tape position. If so, select "YES" by pressing ENTER. If you want data read from a different address, select "NO" by pressing CANCEL. The RESTORE ADDRESS screen reappears.

6 The following screen appears:

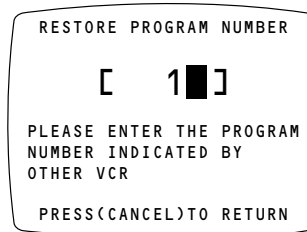

Using the DIGIT buttons, input the Program Number of the back-up tape. Then press ENTER.

NOTE: If the second VCR does not indicate a Program Number, press ENTER in step **5** without inputting anything.

7 The following screens appear:

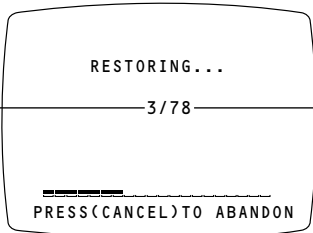
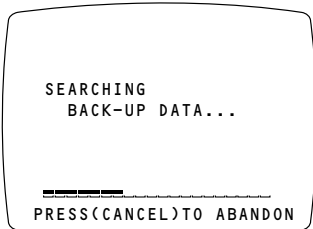

number of titles remaining

total number of titles

To quit the process, press CANCEL.

- Pressing CANCEL at the first screen in step **7** returns you to the normal screen.
- Pressing CANCEL at the second screen in step **7** brings up the following confirmation screen:

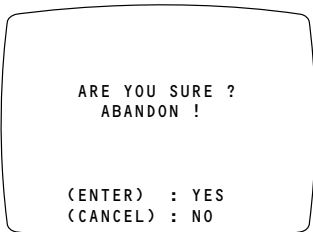

If you are sure you want to stop, select "YES" by pressing ENTER. (The FAILURE screen appears. Press CANCEL.)

If you change your mind, select "NO" by pressing CANCEL. The RESTORING screen appears and restoration continues.

8 When copying is finished, "COMPLETE" appears on screen. If all directories could not be copied, "FAILURE" appears on screen. Re-perform the procedure from step **1**.

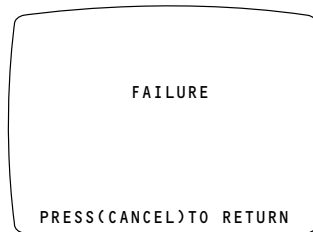
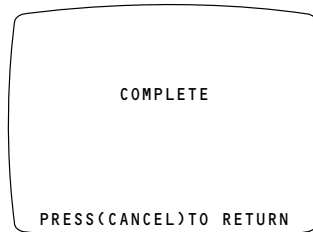

NOTES:

- The directory of the back-up tape used in directory transfer or restore will not copy correctly. To ensure that the back-up tape's own directory is copied correctly, first erase the previously copied version from the VCR's memory (refer to "Erasing A Directory" on page 20 of this instruction manual). Then perform the "Uploading A Directory" procedure (☞ page 23 of this instruction manual).
- If transfer is unsuccessful using the LATEST tape, use the SECOND tape. Any data stored on the tape is completely restored.
- Transferring and restoring may occasionally be unsuccessful, depending on the condition of the tape.
- If you stop a transfer or restoration in progress, it will end incomplete. In this instance you need to initialize the library (☞ pg. 29).

Other Convenient Functions (cont'd)

Disabling INDEX Plus+ Functions

Preparation

1. Turn on the power to the TV and the VCR.
2. Set the TV to the channel or mode appropriate for video playback.
3. Insert an HR tape.

Procedure

- 1 Press INDEX Plus+. The tape's directory appears.

```

WORLD CUP SOCCER          TAPE#0012
U.S.A VS JAPAN           30 SP
*GERMANY VS UK           45 EP
>JAPAN VS ITALY          95 EP
BRAZIL VS SAUDI~ 110 --
-BLANK SPACE-            80 EP
                           PAGE01
(PLAY)(STOP) UTIL. MORE
PRESS(INDEXPlus+)TO EXIT
    
```

Press F3.

- 2 The UTILITY screen appears.

```

          UTILITY
1 IMPORT OTHER LIBRARY
2 DISABLE INDEX PLUS+
3 ERASE LIBRARY
4 BACK-UP INFORMATION

MEMORY USED  ---
PRESS(1),(2),(3)or(4)
PRESS(CANCEL)TO RETURN
    
```

Press 2.

- 3 The screen to the right appears:

```

          DISABLE INDEX PLUS+
                    FUNCTIONS

TO DISABLE INDEX PLUS+
FUNCTIONS,PRESS(ENTER)

PRESS(CANCEL)TO RETURN
    
```

Press ENTER. Or press CANCEL to return to the UTILITY screen.

- 4 The screen to the right appears:

```

INDEX PLUS+ FUNCTIONS
ARE DISABLED. NO INDEX
WILL BE CREATED WHEN
YOU RECORD A PROGRAM.

INDEX PLUS+ MODE WILL
BE REACTIVATED WHEN
YOU CALL UP INDEX PLUS+
FUNCTION.
PRESS(CANCEL)TO RETURN
    
```

- 5 Press CANCEL to return to the normal screen.

All INDEX Plus+ functions are now disabled.

Re-enabling INDEX Plus+ Functions

Procedure

- 1 When INDEX Plus+ is disabled, press INDEX Plus+.
- 2 The screen to the right appears:

```

          INDEX PLUS+ FUNCTIONS
                    ARE DISABLED

PRESS(ENTER)TO ENABLE
PRESS(CANCEL)TO RETURN
    
```

To re-enable INDEX Plus+, press ENTER. Or press CANCEL to return to the normal screen.

NOTE: You can also re-enable INDEX Plus+ by choosing "ON" at the INDEX PLUS+ FUNCTIONS SETTING screen (pg. 9).

ATTENTION

When combining the contents of several tapes recognized by this VCR's library into one tape, make sure that you set INDEX PLUS+ FUNCTIONS to ON and use this VCR as the recorder. If you record with INDEX PLUS+ FUNCTIONS set to OFF, or if you use a non-INDEX Plus+ VCR as the recorder, you must set INDEX PLUS+ FUNCTIONS to OFF to playback on this VCR, or problems will arise in the library.

Initializing The Library

In order to make room for data from another INDEX Plus+ VCR's directory, you can eliminate all data currently in the library.

Preparation

1. Turn on the power to the TV and the VCR.
2. Set the TV to the channel or mode appropriate for video playback.
3. Insert an HR tape.

Procedure

- 1 Press INDEX Plus+. The tape's directory appears.

```

WORLD CUP SOCCER
                TAPE#0012
U.S.A VS JAPAN   30 SP
*GERMANY VS UK   45 EP
>JAPAN VS ITALY  95 EP
BRAZIL VS SAUDI → 110 --
-BLANK SPACE-    80 EP
                PAGE01
(PLAY)(STOP) [X]UTIL.[X]MORE
PRESS(INDEXPlus+)TO EXIT
    
```

Press F3.

- 2 The UTILITY screen appears.

```

                UTILITY
1 IMPORT OTHER LIBRARY
2 DISABLE INDEX PLUS+
3 ERASE LIBRARY
4 BACK-UP INFORMATION

MEMORY USED  ==
PRESS(1),(2),(3)or(4)
PRESS(CANCEL)TO RETURN
    
```

Press 3.

NOTES:

- At the bottom of the screen, the amount of memory currently being used is shown. It begins blinking when there's no memory space open.
- If you press 1, the "WARNING" screen that comes up when you import another library appears.

- 3 The following screen (red background) appears:

```

                ERASE LIBRARY
TO ERASE LIBRARY,
                PRESS(CLEAR)

IF YOU ACTIVATE THIS
FUNCTION,ALL DATA WILL
BE ERASED!

PRESS(CANCEL)TO CANCEL
    
```

Press CLEAR to continue, or press CANCEL to return to the UTILITY screen.

- 4 The following screen (red background) appears:

```

                ERASE LIBRARY

ERASE ALL LIBRARY DATA !

                ARE YOU SURE ?

                (ENTER) : YES
                (CANCEL) : NO
    
```

The VCR gives you one chance to change your mind, as initializing the library erases all data currently stored there. To go ahead and initialize, select YES by pressing ENTER, then proceed to step 5. If you change your mind, select NO by pressing CANCEL. The UTILITY screen reappears.

- 5 If there's a tape with the library's back-up information on it, a screen like this one appears:

```

                BACK-UP INFORMATION

PLEASE WRITE DOWN FOR
                FUTURE RESTORATION

                TAPE# ADDRESS PRG#
LATEST 1468 01234 0012
SECOND 1382 12345 0135

(ENTER):OK (CANCEL):STOP
    
```

To make sure you can restore the original library at some point in the future, copy down the back-up tape's Tape Number, Address Number and Program Number. After writing down the numbers, press ENTER. Or press CANCEL to return to the UTILITY screen.

Continued on next page.

Other Convenient Functions (cont'd)

6 The following screen appears:



Once initialization is complete, this screen appears for a few seconds, and the normal screen reappears.

NOTE: If you want to restore your VCR's library again, perform the "Transferring Directories" procedure on page 26.

Confirming Status Of Back-Up

If you purchase a new INDEX Plus+ VCR, you will wish to maintain the same indexing information for your tape library. This information is available on your latest recorded tape. You must, therefore, know which is the back-up tape for your current VCR's library so that you can copy it into the new VCR.

The following procedure explains how to search for recently-saved data.

Preparation

1. Turn on the power to the TV and the VCR.
2. Set the TV to the channel or mode appropriate for video playback.
3. Insert an HR tape.

Procedure

1 Press INDEX Plus+. The tape's directory appears.

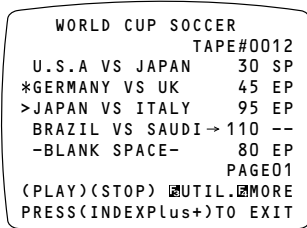

Press F3.

2 The UTILITY screen appears.

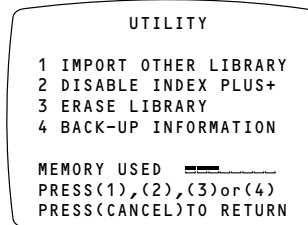

Press 4.

3 The following screen appears:

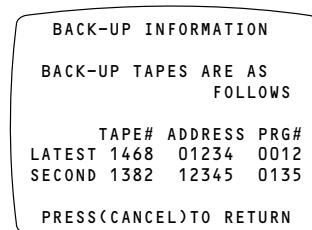

The Tape Numbers, Address Numbers and Program Numbers of the two most recent sets of data are displayed. Press INDEX Plus+ to return to the normal screen.

Restoring Lost Data

When recording using INDEX Plus+, your VCR writes all directory data directly onto the tape. In the unlikely event that data that was stored in the VCR's memory is lost, it can be restored to memory from the last recorded tape. Perform the following procedure to restore data to memory.

Preparation

1. Turn on the power to the TV and the VCR.
2. Set the TV to the channel or mode appropriate for video playback.

Procedure

- 1 Press INDEX Plus+. A screen like this appears:

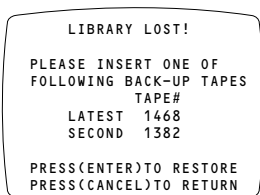

The Tape Numbers of the two most recent additions to memory are displayed.

- 2 To initiate restoration, insert the tape corresponding to the Tape Number that appears to the right of "LATEST", or press CANCEL to return to the normal screen.

- 3 The following screens appear:

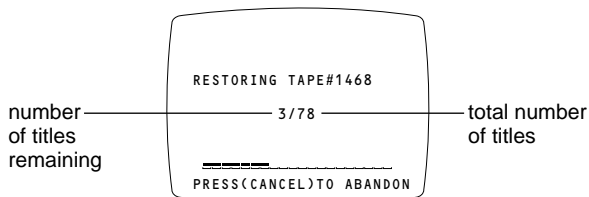
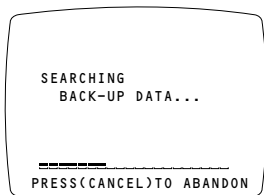
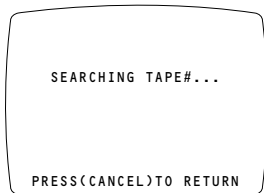

To quit the process, press CANCEL.

- Pressing CANCEL at the first and second screens in step 3 returns you to the normal screen.
- Pressing CANCEL at the third screen in step 3 brings up the following confirmation screen:

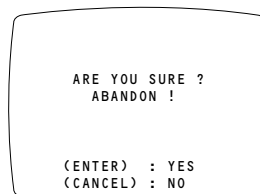

If you're sure you want to stop, select "YES" by pressing ENTER. The FAILURE screen appears. Press CANCEL to return to the normal screen. If you decide not to abandon the process, select "NO" by pressing CANCEL. The RESTORING TAPE#... screen reappears and restoration continues.

Upon completion of restoration, the screen to the right appears:



Once restoration is complete, press CANCEL to return to the normal screen.

NOTES:

- The directory for the back-up tape used in data restoration will not copy correctly. To ensure that the back-up tape's own directory is copied correctly, first erase the previously copied version from the VCR's memory (refer to "Erasing A Directory" on page 21 of this instruction manual). Then perform the "Uploading A Directory" procedure (pg. 23 of this instruction manual).
- Transferring and restoring may occasionally be unsuccessful, depending on the condition of the tape.
- If restoration is unsuccessful using the LATEST tape, use the SECOND tape. Any data stored on that tape is completely restored.
- Restoring may occasionally be unsuccessful, depending on the condition of the tape.
- If you stop a restoration in progress, it ends incomplete. In this instance you need to initialize the library (pg. 29).

Restoring Lost Data (cont'd)

Error Messages

One or more of the following messages may appear during the procedure:

- If you press ENTER in step **2** without having inserted a tape, the SEARCHING TAPE screen from step **3** is followed by this message:

```

NO CASSETTE

PRESS(CANCEL)TO RETURN
  
```

- If you mistakenly inserted a PR tape or a non-INDEX Plus+ tape, after ejecting the tape, the SEARCHING TAPE screen is followed by one of two messages:

```

THIS TAPE IS
A PRE-RECORDED TAPE

PRESS(CANCEL)TO RETURN
  
```

```

THIS TAPE IS
A NON-INDEX PLUS+ TAPE
  
```

Insert the correct tape.

- If the number of the inserted tape can't be read by the VCR, the SEARCHING TAPE screen is followed by this message:

```

THIS TAPE# CAN NOT
BE READ
PLEASE INSERT ONE OF
FOLLOWING BACK-UP TAPES
TAPE#
LATEST 1468
SECOND 1382

PRESS(ENTER)TO RESTORE
PRESS(CANCEL)TO RETURN
  
```

Insert the correct tape.

- If you insert several different incorrect tapes, or the same one repeatedly, this screen follows the SEARCHING TAPE screen:

```

TAPE NUMBER ERROR

AGAIN!

PRESS(ENTER)TO TRY
THIS TAPE AGAIN

PRESS(CANCEL)TO RETURN
  
```

Press CANCEL, then re-perform the procedure from step **1**.

- If you inserted the wrong HR tape, the SEARCHING TAPE screen is followed by this screen:

```

THIS TAPE# IS NOT
CORRECT
PLEASE INSERT ONE OF
FOLLOWING BACK-UP TAPES
TAPE#
LATEST 1468
SECOND 1382

PRESS(ENTER)TO RESTORE
PRESS(CANCEL)TO RETURN
  
```

Insert the correct tape.

- If the data could not be restored, the following screen appears.

```

FAILURE

PRESS(CANCEL)TO RETURN
  
```

Press CANCEL, then re-perform the procedure from step **1**.

Helpful terms and information

The following glossary is to help you better understand INDEX Plus+ and its operation.

INDEX Plus+: The name for the system described in this manual. The system was designed to give you random access to recorded programs, and to make it easy for you to organize your video library (see "library" below).

CSPG (Channel-Specific Program Guide): A listing of upcoming programs on the currently-selected channel. If sent by the broadcaster, this listing can be displayed on screen, and you can use the data for timer recording.

PRI (Program-Related Information): Information relevant to the program currently being received. If the broadcaster is sending this information, you can access it and display it on screen. Typical PRI includes a particular player's statistics from a sporting event, recipes or techniques from a cooking show, or questions and answers from an educational program.

HR (Home-Recorded) Tape: A tape containing programs you've recorded at home on an INDEX Plus+ VCR.

PR (Pre-Recorded) Tape: A tape produced by a video publisher, and available for purchase, which contains an INDEX Plus+ directory (see "directory" below).

RI (Retroactively-Indexed) Tape: A tape consisting of programs recorded at home on a non-INDEX Plus+ VCR. You can add INDEX Plus+ data to this type of tape using the HR-IP820U.

Library: This term describes a person's entire video collection, including HR and PR tapes.

Directory: A listing of all programs contained on a particular tape. The listing can be called to the screen, and contains such information as tape name and number, program names, and each program's recording mode.

Download: The capability of receiving CSPG and storing it in the VCR's internal memory, for easy access at a later time.

Preferred channel: If you live in an area in which a great many regular and cable TV channels are available, the title data for these stations may exceed the VCR's memory capacity. To prepare for this, you can select preferred channels. In the event of memory overload, the data for the channel(s) you select will be kept.

Host station: A data center which receives information from regular and cable TV broadcasters, and sends it, along with the host station's own CSPG and PRI, to users of INDEX Plus+. Each host station covers a specific region.

VISS (VHS Index Search System): A VISS mark, or index mark, is written on the tape during recording. Its purpose is to indicate to the VCR, during playback, that a new program is beginning. VISS marks are always written on HR and RI tapes, but are optional on PR tapes.

On-Screen Menu System: The specially-designed screens, at which required data can be input and functions or options selected, make INDEX Plus+ operations easy to perform.

RF (Radio Frequency) Connection: This describes the VCR-to-TV connection where the RF OUT terminal of the VCR is connected to the ANTENNA terminal of the TV. When this method of connection is employed, the VCR essentially "broadcasts" the program to your TV on channel 3 or 4.

AV (Audio/Video) Connection: This describes the VCR-to-TV connection where the AUDIO OUT and VIDEO OUT terminals of the VCR are connected to the AV IN terminals of the TV. As the audio and video signals are sent independently and directly to the TV, there's no need to convert them into RF signals.

Tuner: Off-the-air and cable TV signals are received by this section of the VCR. This VCR's Frequency-Synthesized Tuner is extremely accurate, and has a maximum reception capability of 181 channels.

Mode: The word used to describe the operational status of the VCR at any given time. For example, when the tape is being rewound, the VCR is in the Rewind mode.

VCR Plus+: The easy timer-programming system which allows you to set your VCR by simply inputting the desired program's code number from the TV listings in newspapers and magazines.

Cable Box: This box serves as a control unit for cable TV subscribers, and is usually placed on or near the TV.

Cable Box Controller: A remote unit that sends signals to the cable box during timer recording.

Guide Channel: The number assigned to a TV broadcaster for purposes of VCR Plus+ programming. This number must match the number of the channel on which your VCR receives the station before you can use VCR Plus+ to record programs shown on that particular station.

Troubleshooting

If one of these screens appears . . .

If, during Host Station Download Scanning, clock setting is unsuccessful, a screen like the following one appears. Host Station Download Scanning is not possible unless the clock is set correctly, so please set manually. (Refer to pg. 9 of the HR-IP820U instruction manual.) Then re-perform the Host Station Download Scanning procedure (☞ pg. 6).

```

AUTOMATIC CLOCK SET
FAILURE

PLEASE SET MANUALLY
THEN TRY AGAIN

PRESS(CANCEL)TO RETURN
  
```

If Guide Channel setting was unsuccessful, a screen like the following one appears after Host Station Download Scanning. Set the Guide Channel manually. (Refer to pg. 15 of the HR-IP820U instruction manual.)

```

AUTOMATIC GUIDE CHANNEL
SETTING IS NOT AVAILABLE

PLEASE SET MANUALLY

PRESS(CANCEL)TO RETURN
  
```

If for some reason all library data is lost, a screen like the following one appears. Restore the lost data (☞ pg. 31).

```

LIBRARY LOST!

PLEASE INSERT ONE OF
FOLLOWING BACK-UP TAPES
    TAPE#
LATEST  1468
SECOND  1382

PRESS(ENTER)TO RESTORE
PRESS(CANCEL)TO RETURN
  
```

When the library becomes full, a screen like the following one appears. In order to create new directories, you have to cancel some of the existing ones (☞ pg. 21).

```

LIBRARY IS FULL !

TO CREATE NEW DIRECTORY,
PLEASE DELETE SOME
DIRECTORIES.

PRESS(CANCEL)TO RETURN
  
```

If a problem occurs with INDEX Plus+, a screen like the following one appears. Please consult your nearest JVC service center.

```

INDEX PLUS+ FUNCTIONS
FAILURE

PLEASE CONSULT THE
NEAREST JVC SERVICE
CENTER
  
```

Memo

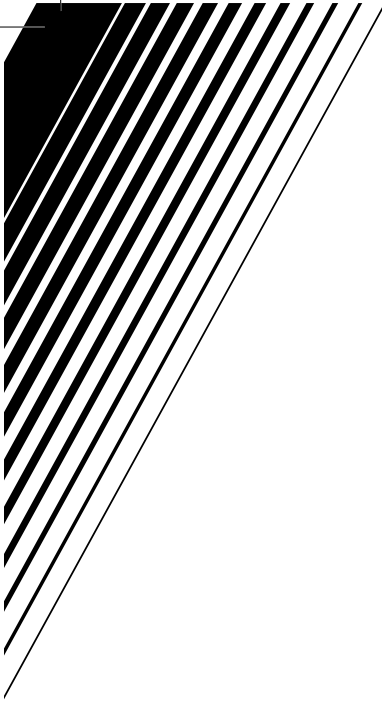

INDEX Plus+ System

JVC

JVC COMPANY OF AMERICA
DIVISION OF US JVC CORP.
41 Slater Drive, Elmwood Park, N.J. 07407

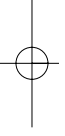

U.S. PATENTS		
4034276	4092684	4829419
4064537	4120583	4896260
4068257	4121284	4942576
4079412	4178606	4954951
4091426		
Canada Patented (Breveté), 1979, 1980		

COPYRIGHT © 1996 VICTOR COMPANY OF JAPAN, LTD.

  Printed In Japan
0396HOV*UN*PJ

